**Hexagon head screws — Product grades
A and B**

Vis à tête hexagonale entièrement filetées — Grades A et B



Reference number
ISO 4017:2011(E)

© ISO 2011



COPYRIGHT PROTECTED DOCUMENT

© ISO 2011

All rights reserved. Unless otherwise specified, no part of this publication may be reproduced or utilized in any form or by any means, electronic or mechanical, including photocopying and microfilm, without permission in writing from either ISO at the address below or ISO's member body in the country of the requester.

ISO copyright office
Case postale 56 • CH-1211 Geneva 20
Tel. + 41 22 749 01 11
Fax + 41 22 749 09 47
E-mail copyright@iso.org
Web www.iso.org

Published in Switzerland

Foreword

ISO (the International Organization for Standardization) is a worldwide federation of national standards bodies (ISO member bodies). The work of preparing International Standards is normally carried out through ISO technical committees. Each member body interested in a subject for which a technical committee has been established has the right to be represented on that committee. International organizations, governmental and non-governmental, in liaison with ISO, also take part in the work. ISO collaborates closely with the International Electrotechnical Commission (IEC) on all matters of electrotechnical standardization.

International Standards are drafted in accordance with the rules given in the ISO/IEC Directives, Part 2.

The main task of technical committees is to prepare International Standards. Draft International Standards adopted by the technical committees are circulated to the member bodies for voting. Publication as an International Standard requires approval by at least 75 % of the member bodies casting a vote.

Attention is drawn to the possibility that some of the elements of this document may be the subject of patent rights. ISO shall not be held responsible for identifying any or all such patent rights.

ISO 4017 was prepared by Technical Committee ISO/TC 2, *Fasteners*, Subcommittee SC 10, *Product standards for fasteners*.

This fourth edition cancels and replaces the third edition (ISO 4017:1999), of which it constitutes a minor revision.

www.iso.org

Introduction

This International Standard belongs to a complete family of product standards developed by ISO on external hexagon drive fasteners. It comprises the following:

- a) hexagon head bolts (ISO 4014, ISO 4015, ISO 4016 and ISO 8765);
- b) hexagon head screws (ISO 4017, ISO 4018 and ISO 8676);
- c) hexagon nuts (ISO 4032, ISO 4033, ISO 4034, ISO 4035, ISO 4036, ISO 7040, ISO 7041, ISO 7042, ISO 7719, ISO 7720, ISO 8673, ISO 8674, ISO 8675, ISO 10511, ISO 10512 and ISO 10513);
- d) hexagon bolts with flange (ISO 4162, ISO 15071 and ISO 15072);
- e) hexagon nuts with flange (ISO 4161, ISO 7043, ISO 7044, ISO 10663, ISO 12125, ISO 12126 and ISO 21670).

Hexagon head screws — Product grades A and B

1 Scope

This International Standard specifies the characteristics of hexagon head screws with threads from M1,6 up to and including M64, of product grade A for threads M1,6 to M24 and nominal lengths up to and including $10d$ or 150 mm, whichever is the shorter, and product grade B for threads over M24 or nominal lengths over $10d$ or 150 mm, whichever is the shorter.

NOTE This type of product is the same as that covered by ISO 4014 with the exception of threading up to head and nominal lengths up to and including 200 mm as preferred lengths.

If, in special cases, specifications other than those listed in this International Standard are required, they can be selected from existing International Standards, for example ISO 724, ISO 888, ISO 898-1, ISO 965-1, ISO 3506-1, ISO 4753 and ISO 4759-1.

2 Normative references

The following referenced documents are indispensable for the application of this document. For dated references, only the edition cited applies. For undated references, the latest edition of the referenced document (including any amendments) applies.

ISO 225, *Fasteners — Bolts, screws, studs and nuts — Symbols and descriptions of dimensions*

ISO 724, *ISO general-purpose metric screw threads — Basic dimensions*

ISO 898-1, *Mechanical properties of fasteners made of carbon steel and alloy steel — Part 1: Bolts, screws and studs with specified property classes — Coarse thread and fine pitch thread*

ISO 965-1, *ISO general-purpose metric screw threads — Tolerances — Part 1: Principles and basic data*

ISO 3269, *Fasteners — Acceptance inspection*

ISO 3506-1, *Mechanical properties of corrosion-resistant stainless steel fasteners — Part 1: Bolts, screws and studs*

ISO 3508, *Thread run-outs for fasteners with thread in accordance with ISO 261 and ISO 262*

ISO 4042, *Fasteners — Electroplated coatings*

ISO 4753, *Fasteners — Ends of parts with external ISO metric thread*

ISO 4759-1, *Tolerances for fasteners — Part 1: Bolts, screws, studs and nuts — Product grades A, B and C*

ISO 6157-1, *Fasteners — Surface discontinuities — Part 1: Bolts, screws and studs for general requirements*

ISO 8839, *Mechanical properties of fasteners — Bolts, screws, studs and nuts made of non-ferrous metals*

ISO 8992, *Fasteners — General requirements for bolts, screws, studs and nuts*

ISO 10683, *Fasteners — Non-electrolytically applied zinc flake coatings*

3 Dimensions

See Figure 1 and Tables 1 and 2.

Symbols and descriptions of dimensions are specified in ISO 225.

Dimensions in millimetres

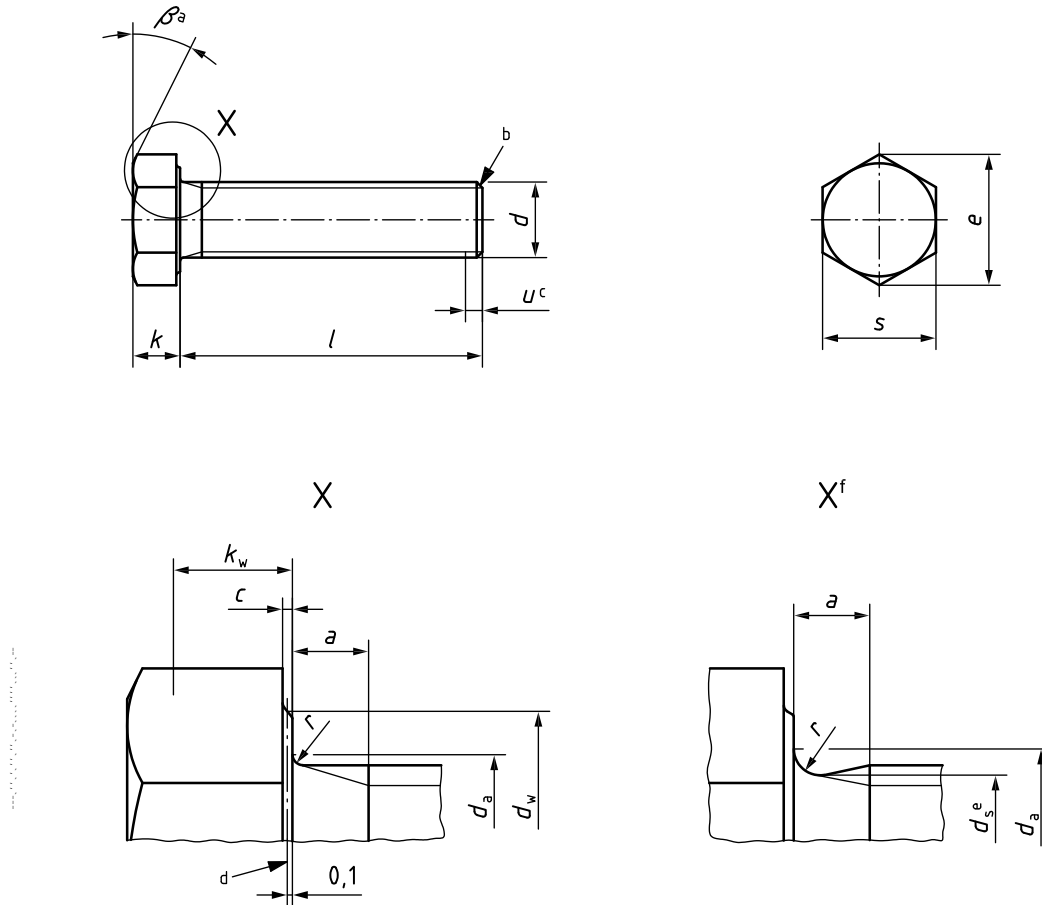

- a $\beta = 15^\circ$ to 30° .
- b Point shall be chamfered or for threads $\leq M4$ may be as-rolled (sheared end) in accordance with ISO 4753.
- c Incomplete thread $u \leq 2P$.
- d Reference datum for d_w .
- e $d_s \approx$ pitch diameter.
- f Permissible shape.

Figure 1

Table 1 — Preferred threads

Dimensions in millimetres

Thread, <i>d</i>				M1,6	M2	M2,5	M3	M4	M5	M6	
<i>p</i> ^a				0,35	0,4	0,45	0,5	0,7	0,8	1	
<i>a</i>			max. ^b	1,05	1,2	1,35	1,5	2,1	2,4	3	
			min.	0,35	0,4	0,45	0,5	0,7	0,8	1	
<i>c</i>			max.	0,25	0,25	0,25	0,40	0,40	0,50	0,50	
			min.	0,10	0,10	0,10	0,15	0,15	0,15	0,15	
<i>d</i> _a			max.	2	2,6	3,1	3,6	4,7	5,7	6,8	
<i>d</i> _w	Product grade	A	min.	2,27	3,07	4,07	4,57	5,88	6,88	8,88	
		B		2,30	2,95	3,95	4,45	5,74	6,74	8,74	
<i>e</i>	Product grade	A	min.	3,41	4,32	5,45	6,01	7,66	8,79	11,05	
		B		3,28	4,18	5,31	5,88	7,50	8,63	10,89	
<i>k</i>		Product grade	A	nom.	1,1	1,4	1,7	2	2,8	3,5	4
				max.	1,225	1,525	1,825	2,125	2,925	3,65	4,15
	Product grade	B	max.	1,3	1,6	1,9	2,2	3,0	3,74	4,24	
			min.	0,9	1,2	1,5	1,8	2,6	3,26	3,76	
<i>k</i> _w ^c	Product grade	A	min.	0,68	0,89	1,10	1,31	1,87	2,35	2,70	
		B		0,63	0,84	1,05	1,26	1,82	2,28	2,63	
<i>r</i>			min.	0,1	0,1	0,1	0,1	0,2	0,2	0,25	
<i>s</i>	Product grade	A	min.	nom. = max.	3,20	4,00	5,00	5,50	7,00	8,00	10,00
				B	3,02	3,82	4,82	5,32	6,78	7,78	9,78
					2,90	3,70	4,70	5,20	6,64	7,64	9,64
Product grade											
A											
B											
<i>l</i>											
nom.	min.	max.	min.	max.							
2	1,8	2,2	—	—							
3	2,8	3,2	—	—							
4	3,76	4,24	—	—							
5	4,76	5,24	—	—							
6	5,76	6,24	—	—							
8	7,71	8,29	—	—							
10	9,71	10,29	—	—							
12	11,65	12,35	—	—							
16	15,65	16,35	—	—							
20	19,58	20,42	18,95	21,05							
25	24,58	25,42	23,95	26,05							
30	29,58	30,42	28,95	31,05							
35	34,5	35,5	33,75	36,25							
40	39,5	40,5	38,75	41,25							
45	44,5	45,5	43,75	46,25							
50	49,5	50,5	48,75	51,25							
55	54,4	55,6	53,5	56,5							
60	59,4	60,6	58,5	61,5							
65	64,4	65,6	63,5	66,5							
70	69,4	70,6	68,5	71,5							
80	79,4	80,6	78,5	81,5							
90	89,3	90,7	88,25	91,75							
100	99,3	100,7	98,25	101,75							
110	109,3	110,7	108,25	111,75							
120	119,3	120,7	118,25	121,75							
130	129,2	130,8	128	132							
140	139,2	140,8	138	142							
150	149,2	150,8	148	152							
160	—	—	158	162							
180	—	—	178	182							
200	—	—	197,7	202,3							

Table 1 (continued)

Dimensions in millimetres

Thread, <i>d</i>				M8	M10	M12	M16	M20	M24	
<i>p</i> ^a				1,25	1,5	1,75	2	2,5	3	
<i>a</i>	max. ^b			4	4,5	5,3	6	7,5	9	
	min.			1,25	1,5	1,75	2	2,5	3	
<i>c</i>	max.			0,15	0,15	0,15	0,2	0,2	0,2	
	min.			0,6	0,6	0,6	0,8	0,8	0,8	
<i>d</i> _a				max.	9,2	11,2	13,7	17,7	22,4	26,4
<i>d</i> _w	Product grade	A	min.	11,63	14,63	16,63	22,49	28,19	33,61	
		B		11,47	14,47	16,47	22	27,7	33,25	
<i>e</i>	Product grade	A	min.	14,38	17,77	20,03	26,75	33,53	39,98	
		B		14,20	17,59	19,85	26,17	32,95	39,55	
<i>k</i>	Product grade	A	nom.	5,3	6,4	7,5	10	12,5	15	
			max.	5,45	6,58	7,68	10,18	12,715	15,215	
		B	min.	5,15	6,22	7,32	9,82	12,285	14,785	
			max.	5,54	6,69	7,79	10,29	12,85	15,35	
<i>k</i> _w ^c	Product grade	A	min.	3,61	4,35	5,12	6,87	8,6	10,35	
		B		3,54	4,28	5,05	6,8	8,51	10,26	
<i>r</i>				min.	0,4	0,4	0,6	0,6	0,8	0,8
<i>s</i>	nom. = max.			13,00	16,00	18,00	24,00	30,00	36,00	
	Product grade	A	min.	12,73	15,73	17,73	23,67	29,67	35,38	
		B		12,57	15,57	17,57	23,16	29,16	35	
Product grade										
				A		B				
				<i>l</i>						
nom.	min.	max.		min.	max.					
2	1,8	2,2	—	—	—					
3	2,8	3,2	—	—	—					
4	3,76	4,24	—	—	—					
5	4,76	5,24	—	—	—					
6	5,76	6,24	—	—	—					
8	7,71	8,29	—	—	—					
10	9,71	10,29	—	—	—					
12	11,65	12,35	—	—	—					
16	15,65	16,35	—	—	—					
20	19,58	20,42	18,95	21,05	—					
25	24,58	25,42	23,95	26,05	—					
30	29,58	30,42	28,95	31,05	—					
35	34,5	35,5	33,75	36,25	—					
40	39,5	40,5	38,75	41,25	—					
45	44,5	45,5	43,75	46,25	—					
50	49,5	50,5	48,75	51,25	—					
55	54,4	55,6	53,5	56,5	—					
60	59,4	60,6	58,5	61,5	—					
65	64,4	65,6	63,5	66,5	—					
70	69,4	70,6	68,5	71,5	—					
80	79,4	80,6	78,5	81,5	—					
90	89,4	90,7	88,25	91,75	—					
100	99,3	100,7	98,25	101,75	—					
110	109,3	110,7	108,25	111,75	—					
120	119,3	120,7	118,25	121,75	—					
130	129,2	130,8	128	132	—					
140	139,2	140,8	138	142	—					
150	149,2	150,8	148	152	—					
160	—	—	158	162	—					
180	—	—	178	182	—					
200	—	—	197,7	202,3	—					

Table 1 (continued)

Dimensions in millimetres

Thread, <i>d</i>			M30	M36	M42	M48	M56	M64	
<i>P</i> ^a			3,5	4	4,5	5	5,5	6	
<i>a</i>		max. ^b	10,5	12	13,5	15	16,5	18	
		min.	3,5	4	4,5	5	5,5	6	
<i>c</i>		max.	0,2	0,2	0,3	0,3	0,3	0,3	
		min.	0,8	0,8	1	1	1	1	
<i>d_a</i>		max.	33,4	39,4	45,6	52,6	63	71	
<i>d_w</i>	Product grade	A	—	—	—	—	—	—	
		B	min.	42,75	51,11	59,95	69,45	78,66	88,16
<i>e</i>	Product grade	A	—	—	—	—	—	—	
		B	min.	50,85	60,79	71,3	82,6	93,56	104,86
<i>k</i>	Product grade	A	nom.	18,7	22,5	26	30	35	40
			max.	—	—	—	—	—	—
	Product grade	B	max.	19,12	22,92	26,42	30,42	35,5	40,5
			min.	18,28	22,08	25,58	29,58	34,5	39,5
<i>k_w</i> ^c	Product grade	A	—	—	—	—	—	—	
		B	min.	12,8	15,46	17,91	20,71	24,15	27,65
<i>r</i>		min.	1	1	1,2	1,6	2	2	
		nom. = max.	46	55,0	65,0	75,0	85,0	95,0	
<i>s</i>	Product grade	A	—	—	—	—	—	—	
		B	min.	45	53,8	63,1	73,1	82,8	92,8
Product grade									
A									
B									
<i>l</i>									
nom.	min.	max.	min.	max.					
2	1,8	2,2	—	—					
3	2,8	3,2	—	—					
4	3,76	4,24	—	—					
5	4,76	5,24	—	—					
6	5,76	6,24	—	—					
8	7,71	8,29	—	—					
10	9,71	10,29	—	—					
12	11,65	12,35	—	—					
16	15,65	16,35	—	—					
20	19,58	20,42	18,95	21,05					
25	24,58	25,42	23,95	26,05					
30	29,58	30,42	28,95	31,05					
35	34,5	35,5	33,75	36,25					
40	39,5	40,5	38,75	41,25					
45	44,5	45,5	43,75	46,25					
50	49,5	50,5	48,75	51,25					
55	54,4	55,6	53,5	56,5					
60	59,4	60,6	58,5	61,5					
65	64,4	65,6	63,5	66,5					
70	69,4	70,6	68,5	71,5					
80	79,4	80,6	78,5	81,5					
90	89,3	90,7	88,25	91,75					
100	99,3	100,7	98,25	101,75					
110	109,3	110,7	108,25	111,75					
120	119,3	120,7	118,25	121,75					
130	129,2	130,8	128	132					
140	139,2	140,8	138	142					
150	149,2	150,8	148	152					
160	—	—	158	162					
180	—	—	178	182					
200	—	—	197,7	202,3					
<p>NOTE The range of preferred lengths is between the solid, bold, stepped line: — for product grade A, above the discontinuous, stepped line; — for product grade B, below this line.</p>									
<p>^a <i>P</i> is the pitch of the thread. ^b Values in accordance with <i>a_{max}</i>, normal series, in ISO 3508. ^c <i>k_{w,min}</i> = 0,7 <i>k_{min}</i></p>									

Table 2 — Non-preferred threads

Dimensions in millimetres

Thread, <i>d</i>					M3,5	M14	M18	M22	M27
<i>p</i> ^a					0,6	2	2,5	2,5	3
<i>a</i>	max. ^b				1,8	6	7,5	7,5	9
	min.				0,6	2	2,5	2,5	3
<i>c</i>	max.				0,15	0,15	0,2	0,2	0,2
	min.				0,4	0,6	0,8	0,8	0,8
<i>d</i> _a					max.				
<i>d</i> _w	Product grade	A		min.	5,07	19,64	25,34	31,71	—
		B			4,95	19,15	24,85	31,35	38
<i>e</i>	Product grade	A		min.	6,58	23,36	30,14	37,72	—
		B			6,44	22,78	29,56	37,29	45,2
<i>k</i>	nom.				2,4	8,8	11,5	14	17
	Product grade	A		max.	2,525	8,98	11,715	14,215	—
		B			2,2	8,51	11,15	13,65	16,65
	Product grade	A		min.	2,275	8,62	11,285	13,785	—
B		2,6	9,09		11,85	14,35	17,35		
<i>k</i> _w ^c	Product grade	A		min.	1,59	6,03	7,9	9,65	—
		B			1,54	5,96	7,81	9,56	11,66
<i>r</i>					min.				
<i>s</i>	nom. = max.				6,00	21,00	27,00	34,00	41,00
	Product grade	A		min.	5,82	20,67	26,67	33,38	—
		B			5,70	20,16	26,16	33	40
Product grade									
A B									
<i>l</i>									
nom.	min.	max.	min.	max.					
8	7,71	8,29	—	—					
10	9,71	10,29	—	—					
12	11,65	12,35	—	—					
16	15,65	16,35	—	—					
20	19,58	20,42	—	—					
25	24,58	25,42	—	—					
30	29,58	30,42	—	—					
35	34,5	35,5	—	—					
40	39,5	40,5	38,75	41,25					
45	44,5	45,5	43,75	46,25					
50	49,5	50,5	48,75	51,25					
55	54,4	55,6	53,5	56,5					
60	59,4	60,6	58,5	61,5					
65	64,4	65,6	63,5	66,5					
70	69,4	70,6	68,5	71,5					
80	79,4	80,6	78,5	81,5					
90	89,3	90,7	88,25	91,75					
100	99,3	100,7	98,25	101,75					
110	109,3	110,7	108,25	111,75					
120	119,3	120,7	118,25	121,75					
130	129,2	130,8	128	132					
140	139,2	140,8	138	142					
150	149,2	150,8	148	152					
160	—	—	158	162					
180	—	—	178	182					
200	—	—	197,7	202,3					

Table 2 (continued)

Dimensions in millimetres

Thread, <i>d</i>					M33	M39	M45	M52	M60
<i>p</i> ^a					3,5	4	4,5	5	5,5
<i>a</i>	max. ^b				10,5	12	13,5	15	16,5
	min.				3,5	4	4,5	5	5,5
<i>c</i>	max.				0,2	0,3	0,3	0,3	0,3
	min.				0,8	1	1	1	1
<i>d_a</i>					36,4	42,4	48,6	56,6	67
<i>d_w</i>	Product grade	A		min.	—	—	—	—	—
		B			46,55	55,86	64,7	74,2	83,41
<i>e</i>	Product grade	A		min.	—	—	—	—	—
		B			55,37	66,44	76,95	88,25	99,21
<i>k</i>	Product grade	A		nom.	21	25	28	33	38
		A		max.	—	—	—	—	—
	B		min.	—	—	—	—	—	
	B		max.	21,42	25,42	28,42	33,5	38,5	
<i>k_w</i> ^c	Product grade	A		min.	—	—	—	—	—
		B			14,41	17,21	19,31	22,75	26,25
<i>r</i>					1	1	1,2	1,6	2
nom. = max.					50	60,0	70,0	80,0	90,0
<i>s</i>	Product grade	A		min.	—	—	—	—	—
		B			49	58,8	68,1	78,1	87,8
Product grade									
A									
B									
<i>l</i>									
nom.	min.	max.	min.	max.					
8	7,71	8,29	—	—					
10	9,71	10,29	—	—					
12	11,65	12,35	—	—					
16	15,65	16,35	—	—					
20	19,58	20,42	—	—					
25	24,58	25,42	—	—					
30	29,58	30,42	—	—					
35	34,5	35,5	—	—					
40	39,5	40,5	38,75	41,25					
45	44,5	45,5	43,75	46,25					
50	49,5	50,5	48,75	51,25					
55	54,4	55,6	53,5	56,5					
60	59,4	60,6	58,5	61,5					
65	64,4	65,6	63,5	66,5					
70	69,4	70,6	68,5	71,5					
80	79,4	80,6	78,5	81,5					
90	89,3	90,7	88,25	91,75					
100	99,3	100,7	98,25	101,75					
110	109,3	110,7	108,25	111,75					
120	119,3	120,7	118,25	121,75					
130	129,2	130,8	128	132					
140	139,2	140,8	138	142					
150	149,2	150,8	148	152					
160	—	—	158	162					
180	—	—	178	182					
200	—	—	197,7	202,3					
<p>NOTE The range of preferred lengths is between the solid, bold, stepped line: — for product grade A, above the discontinuous, stepped line; — for product grade B, below this line.</p>									
<p>^a <i>P</i> is the pitch of the thread. ^b Values in accordance with <i>a_{max}</i>, normal series, in ISO 3508. ^c <i>k_{w,min}</i> = 0,7 <i>k_{min}</i></p>									

4 Specifications and reference International Standards

See Table 3.

Table 3 — Specifications and reference International Standards

Material		Steel	Stainless steel	Non-ferrous metal
General requirements	International Standard	ISO 8992		
	Tolerance class	6g		
Thread	International Standard	ISO 724, ISO 965-1		
	Property class ^a	$d < 3$ mm: as agreed $3 \text{ mm} \leq d \leq 39$ mm: 5.6, 8.8, 9.8, 10.9 $d > 39$ mm: as agreed	$d \leq 24$ mm: A2-70, A4-70 $24 \text{ mm} < d \leq 39$ mm: A2-50, A4-50 $d > 39$ mm: as agreed	Materials specified in ISO 8839.
Mechanical property	International Standard	$d \leq 39$ mm: ISO 898-1 $d < 3$ mm and $d > 39$ mm: as agreed	$d \leq 39$ mm: ISO 3506-1 $d > 39$ mm: as agreed	
	Product grade	For $d \leq 24$ mm and $l \leq 10d$ or 150 mm ^b : A For $d > 24$ mm or $l > 10d$ or 150 mm ^b : B		
Tolerance	International Standard	ISO 4759-1		
	Finish — Coating	As processed Requirements for electroplating are specified in ISO 4042. Requirements for non-electrolytically applied zinc flake coatings are specified in ISO 10683. Additional requirements or other finishes or coatings shall be agreed between the supplier and the purchaser.	As processed	As processed Requirements for electroplating are specified in ISO 4042.
Surface integrity	Limits for surface discontinuities are specified in ISO 6157-1.			
Acceptability	Acceptance inspection is specified in ISO 3269.			
^a Other property classes are specified in ISO 898-1 for steel and ISO 3506-1 for stainless steel, respectively. ^b Whichever is the shorter.				

5 Designation

EXAMPLE A hexagon head screw with thread size M12, nominal length $l = 80$ mm and property class 8.8 is designated as follows:

Hexagon head screw ISO 4017 - M12 × 80 - 8.8

Bibliography

- [1] ISO 888, *Bolts, screws and studs — Nominal lengths, and thread lengths for general purpose bolts*
- [2] ISO 4014, *Hexagon head bolts — Product grades A and B*
- [3] ISO 4015, *Hexagon head bolts — Product grade B — Reduced shank (shank diameter approximately equal to pitch diameter)*
- [4] ISO 4016, *Hexagon head bolts — Product grade C*
- [5] ISO 4018, *Hexagon head screws — Product grade C*
- [6] ISO 4032, *Hexagon nuts, style 1 — Product grades A and B*
- [7] ISO 4033, *Hexagon nuts, style 2 — Product grades A and B*
- [8] ISO 4034, *Hexagon nuts — Product grade C*
- [9] ISO 4035, *Hexagon thin nuts (chamfered) — Product grades A and B*
- [10] ISO 4036, *Hexagon thin nuts (unchamfered) — Product grade B*
- [11] ISO 4161, *Hexagon nuts with flange — Coarse thread*
- [12] ISO 4162, *Hexagon flange bolts — Small series*
- [13] ISO 7040, *Prevailing torque type hexagon nuts (with non-metallic insert), style 1 — Property classes 5, 8 and 10*
- [14] ISO 7041, *Prevailing torque type hexagon nuts (with non-metallic insert), style 2 — Property classes 9 and 12*
- [15] ISO 7042, *Prevailing torque type all-metal hexagon nuts, style 2 — Property classes 5, 8, 10 and 12*
- [16] ISO 7043, *Prevailing torque type hexagon nuts with flange (with non-metallic insert) — Product grades A and B*
- [17] ISO 7044, *Prevailing torque type all-metal hexagon nuts with flange — Product grades A and B*
- [18] ISO 7719, *Prevailing torque type all-metal hexagon nuts, style 1 — Property classes 5, 8 and 10*
- [19] ISO 7720, *Prevailing torque type all-metal hexagon nuts, style 2 — Property class 9*
- [20] ISO 8673, *Hexagon nuts, style 1, with metric fine pitch thread — Product grades A and B*
- [21] ISO 8674, *Hexagon nuts, style 2, with metric fine pitch thread — Product grades A and B*
- [22] ISO 8675, *Hexagon thin nuts (chamfered) with metric fine pitch thread — Product grades A and B*
- [23] ISO 8676, *Hexagon head screws with metric fine pitch thread — Product grades A and B*
- [24] ISO 8765, *Hexagon head bolts with metric fine pitch thread — Product grades A and B*
- [25] ISO 10511, *Prevailing torque type hexagon thin nuts (with non-metallic insert)*

ISO 4017:2011(E)

- [26] ISO 10512, *Prevailing torque type hexagon nuts (with non-metallic insert), style 1, with metric fine pitch thread — Property classes 6, 8 and 10*
- [27] ISO 10513, *Prevailing torque type all-metal hexagon nuts, style 2, with metric fine pitch thread — Property classes 8, 10 and 12*
- [28] ISO 10663, *Hexagon nuts with flange — Fine pitch thread*
- [29] ISO 12125, *Prevailing torque type hexagon nuts with flange (with non-metallic insert) with metric fine pitch thread — Product grades A and B*
- [30] ISO 12126, *Prevailing torque type all-metal hexagon nuts with flange with metric fine pitch thread — Product grades A and B*
- [31] ISO 15071, *Hexagon bolts with flange — Small series — Product grade A*
- [32] ISO 15072, *Hexagon bolts with flange with metric fine pitch thread — Small series — Product grade A*
- [33] ISO 21670, *Hexagon weld nuts with flange*

www.iso.org

