

ASME B18.31.1M-2005

# Metric Continuous and Double End Studs

AN AMERICAN NATIONAL STANDARD



The American Society of  
Mechanical Engineers

**ASME B18.31.1M-2005**

# **Metric Continuous and Double End Studs**

**AN AMERICAN NATIONAL STANDARD**



**The American Society of  
Mechanical Engineers**

**Three Park Avenue • New York, NY 10016**

Date of Issuance: February 28, 2006

The next edition of this Standard is scheduled for publication in 2010. There will be no addenda issued to this edition.

ASME issues written replies to inquiries concerning interpretations of technical aspects of this Standard. Interpretations are published on the ASME Web site under the Committee Pages at <http://www.asme.org/codes/> as they are issued.

ASME is the registered trademark of The American Society of Mechanical Engineers.

This code or standard was developed under procedures accredited as meeting the criteria for American National Standards. The Standards Committee that approved the code or standard was balanced to assure that individuals from competent and concerned interests have had an opportunity to participate. The proposed code or standard was made available for public review and comment that provides an opportunity for additional public input from industry, academia, regulatory agencies, and the public-at-large.

ASME does not “approve,” “rate,” or “endorse” any item, construction, proprietary device, or activity.

ASME does not take any position with respect to the validity of any patent rights asserted in connection with any items mentioned in this document, and does not undertake to insure anyone utilizing a standard against liability for infringement of any applicable letters patent, nor assume any such liability. Users of a code or standard are expressly advised that determination of the validity of any such patent rights, and the risk of infringement of such rights, is entirely their own responsibility.

Participation by federal agency representative(s) or person(s) affiliated with industry is not to be interpreted as government or industry endorsement of this code or standard.

ASME accepts responsibility for only those interpretations of this document issued in accordance with the established ASME procedures and policies, which precludes the issuance of interpretations by individuals.

No part of this document may be reproduced in any form,  
in an electronic retrieval system or otherwise,  
without the prior written permission of the publisher.

The American Society of Mechanical Engineers  
Three Park Avenue, New York, NY 10016-5990

Copyright © 2006 by  
THE AMERICAN SOCIETY OF MECHANICAL ENGINEERS  
All rights reserved  
Printed in U.S.A.

# CONTENTS

Foreword .....	iv
Committee Roster .....	vi
Correspondence With the B18 Committee .....	vii
<b>1 Introduction</b> .....	1
<b>2 Comparison With ISO Standards</b> .....	1
<b>3 Referenced Standards</b> .....	1
<b>4 Terminology</b> .....	1
<b>5 Dimensions</b> .....	1
<b>6 Body Diameter</b> .....	2
<b>7 Length</b> .....	2
<b>8 Points</b> .....	2
<b>9 Thread Length</b> .....	2
<b>10 Screw Threads</b> .....	2
<b>11 Materials and Mechanical Properties</b> .....	2
<b>12 Identification Symbols</b> .....	3
<b>13 Finish</b> .....	3
<b>14 Workmanship</b> .....	3
<b>15 Straightness</b> .....	3
<b>16 Inspection and Quality Assurance</b> .....	3
<b>17 Dimensional Conformance</b> .....	3
<b>18 Clearance Holes</b> .....	3
<b>19 Designation</b> .....	3
<b>Tables</b>	
1 Dimensions for Continuous Thread Studs .....	4
2 Dimensions for Clamping Type Studs .....	5
3 Dimensions for Tap End Studs (1.5D Engagement) .....	6
4 Body Dimensions for Double End Studs .....	7
5 Length Tolerances — $L_T$ for Continuous Thread and Clamping Type Studs, and $L$ for Tap End Studs .....	7
<b>Mandatory Appendix</b>	
I Stud Straightness, Referee Gage, and Gaging Procedures .....	8

# FOREWORD

American National Standards Committee B18 for the standardization of bolts, screws, nuts, rivets, and similar fasteners was organized in March 1922 as Sectional Committee B18 under the aegis of the American Engineering Standards Committee (later the American Standards Association, then the United States of America Standards Institute and, as of October 6, 1969, the American National Standards Institute, Inc.) with the Society of Automotive Engineers and the American Society of Mechanical Engineers as joint sponsors.

In 1995 the SAE Ship Systems and Equipment Committee that was preparing fastener part standards for the ship-building industry asked ASME Committee B18 if there was an interest in developing dimensional standards for studs. At the December 1995 B18 meeting in Atlanta, it was reported that a survey by ASME showed considerable interest in establishing a subcommittee to develop stud standards and 11 representatives indicating their willingness to serve on the subcommittee. Subcommittee (SC) 31 was established and drafts of SAE customary and metric stud standards were distributed for review.

The first meeting of SC 31 on studs was held in April 1996 in conjunction with the ASME B18 meetings in Chicago. Existing stud standards (IFI 136 Studs and Bolts and IFI 528 Metric Studs and Bolts) were compared with the draft of SAE standards [J2271 Part Standard for Studs — Continuous and Double End (Inch Series) and J2271M Part Standard for Studs — Continuous and Double End (Metric)]. The subcommittee then identified the configurations to be developed along with thread sizes and diameters to be covered. It was determined to develop both customary and metric standards covering both continuously threaded and double ended studs. A decision to develop the metric standard first was unanimously passed.

An ASME B18, SC 31 Working Group on Metric Studs met at the Defense Industrial Supply Center in Philadelphia in November 1996. Some of the more important recommendations of the working group were

(a) Continuous and Double End Studs (based on newly published SAE J2271M) would be covered and interference-fit studs would not be covered.

(b) Diameters 5 mm through 100 mm would be covered with coarse pitch threads used for diameters of 56 mm and smaller and six pitch threads for larger diameters.

(c) It was agreed that the length should be the overall length as per IFI 528 and SAE J2271 and not the ambiguous first to last thread requirement as identified in ASTM A 193/A 193M.

(d) Cover both finished and unfinished ends and permit sheared ends provided they were suitable for marking.

(e) For double end studs, a thread length of  $1\frac{1}{2}$  diameters on one end and a longer thread length on the other end as per SAE J2271M. The recommendations of the Working Group were accepted at the SC 31 meeting in New Orleans in December 1996 with only minor modifications.

A draft of B18.31.1M was forwarded to members prior to the April 1997 SC 31 meeting in Cleveland and some changes were identified at the meeting. Drafts and changes were reviewed at subsequent meetings.

A draft of B18.31.1M was circulated for ballot prior to the December 1998 SC 31 meeting in Phoenix and discussed at the meeting. A number of changes were identified including placing the figures over the applicable tables. A motion was approved to submit the revised draft to SC 31 and B18 for a simultaneous ballot.

A revised draft was reviewed at the SC 31 meeting in Altamonte Springs, Florida in April 1999 that incorporated changes from the previous meeting and utilized ISO 225 dimensions. The draft was generally accepted and the sponsor was asked to review ISO 4759 tolerances and incorporate as appropriate.

At the December 1999 San Antonio meeting of SC 31, the latest draft of B18.31.1M was reviewed. The addition of a double end (bolt-stud) configuration with threads of equal length was proposed and generally accepted. It was proposed to review Deutsches Institut für Normung e.V. (DIN) stud standards and survey stud manufacturers. After reviewing DIN stud standards, a survey

was developed. The survey was circulated to SC 31 members prior to the May 2000 meeting in Orlando to determine if the survey was suitable for wider circulation. The results of the survey were discussed at the meeting and it was decided that a wider circulation was not required and that a revised draft of the standard based on the recommendations contained in the survey should be balloted.

At the December 2000 SC 31 meeting in New Orleans, a new draft of B18.31.1M was reviewed. As a result the following, significant changes were proposed:

(a) Reference ASTM F 1941M for plating requirements and add smaller diameters down to 1.6 mm.

(b) Circulation of a new draft for SC ballot was approved; this new draft was balloted in April 2001.

(c) Subsequently, to resolve a ballot disapproval, it was proposed that a thread length of  $2D$  plus six threads be added to the tables for double end studs. A revised draft with this and other changes was balloted in November 2001.

Changes included adding the 14 mm diameter for double end studs and 14 mm, 22 mm, and 27 mm diameters added for continuously threaded studs.

The standard was again balloted in March and November 2002. At the December 2002 meeting it was recommended that straightness requirements be added. Subsequently, the ISO tolerances for straightness were deleted in favor of tolerances used in other ASME B18 standards. Minor changes were incorporated as a result of 2003 ballot and a reconsideration ballot in March 2004 closed without responses. A previous disapproval was discussed at the April 2004 meeting and some changes accepted.

At the December 2004 meeting it was agreed to delete ASTM F 2281 as it applies only to inch-dimensioned fasteners. It was also agreed upon to revise the format of several tables to improve consistency of the various tables. The revised document was submitted for another reconsideration ballot in March 2005. This Standard was approved by the American National Standards Institute on November 9, 2005.

# ASME B18 COMMITTEE

## Standardization of Bolts, Nuts, Rivets, Screws, Washers, and Similar Fasteners

(The following is the roster of the Committee at the time of approval of this Standard.)

### OFFICERS

**D. A. Clever**, *Chair*  
**R. D. Strong**, *Vice Chair*  
**S. W. Vass**, *Vice Chair*  
**R. L. Crane**, *Secretary*

### COMMITTEE PERSONNEL

<b>J. Altman</b> , Rotor Clip Co.	<b>W. H. Kopke</b> , ITW Assembly Components
<b>J. H. Slass</b> , <i>Alternate</i> , Rotor Clip Co.	<b>M. Levinson</b> , <i>Alternate</i> , ITW Assembly Components
<b>J. B. Belford</b> , Lawson Products, Inc.	<b>J. G. Langenstein</b> , <i>Member Emeritus</i> , Consultant
<b>V. Cartina</b> , Aztech Locknut	<b>L. L. Lord</b> , <i>Corresponding Member</i> , Consultant
<b>D. A. Clever</b> , Deere and Co.	<b>W. J. Lutkus</b> , Heli Coil Emhart
<b>A. P. Cockman</b> , Ford Motor Co.	<b>D. McCrindle</b> , Canadian Fasteners Institute
<b>T. Collier</b> , Cam-Tech Industries, Inc.	<b>M. D. Prasad</b> , General Motors Corp.
<b>R. L. Crane</b> , The American Society of Mechanical Engineers	<b>J. A. Roley</b> , <i>Corresponding Member</i> , Caterpillar, Inc.
<b>A. C. Dicola</b> , Wrought Washer Co.	<b>W. L. Sakowski</b> , Account Managers, LLC
<b>B. A. Dusina</b> , Federal Screw Works	<b>S. Savoji</b> , ITW Medalist
<b>J. S. Foote</b> , <i>Corresponding Member</i> , Trade Association Management, Inc.	<b>W. Schevey</b> , BGM Fastener Co., Inc.
<b>D. S. George</b> , Ford Motor Co.	<b>W. R. Stevens</b> , Ramco
<b>J. Greenslade</b> , Greenslade and Co.	<b>R. D. Strong</b> , General Motors Corp.
<b>J. J. Grey</b> , Fastener Consulting Services, Inc.	<b>S. W. Vass</b> , Nova Machine Products
<b>B. Hasiuk</b> , Defense Supply Center Philadelphia	<b>C. B. Wackrow</b> , MNP Corp.
<b>A. Herskovitz</b> , Consultant	<b>R. G. Weber</b> , Fairfield University
<b>J. Hubbard</b> , Rockford Fastener, Inc.	<b>W. K. Wilcox</b> , Consultant
<b>M. Keller</b> , <i>Corresponding Member</i> , PARACAD	<b>C. J. Wilson</b> , Industrial Fasteners Institute
<b>J. F. Koehl</b> , Spirol International Corp.	<b>R. B. Wright</b> , Wright Tool Co.
	<b>J. G. Zeratsky</b> , National Rivet and Manufacturing Co.

### SUBCOMMITTEE 31 — THREADED STUDS

<b>W. K. Wilcox</b> , <i>Chair</i> , Consultant	<b>J. Jennings</b> , Naval Surface Warfare Center
<b>R. L. Crane</b> , <i>Secretary</i> , The American Society of Mechanical Engineers	<b>W. Schevey</b> , BGM Fastener Co., Inc.
<b>J. F. Braden</b> , Girard Fastener Co.	<b>G. M. Simpson</b> , Semblex Corp.
<b>D. A. Clever</b> , Deere and Co.	<b>W. R. Stevens</b> , Ramco
<b>D. S. George</b> , Ford Motor Co.	<b>R. D. Strong</b> , General Motors Corp.
<b>J. Greenslade</b> , Greenslade and Co.	<b>C. B. Wackrow</b> , MNP Corp.
<b>A. Herskovitz</b> , Consultant	<b>C. J. Wilson</b> , Industrial Fasteners Institute

# CORRESPONDENCE WITH THE B18 COMMITTEE

**General.** ASME Standards are developed and maintained with the intent to represent the consensus of concerned interests. As such, users of this Standard may interact with the Committee by requesting interpretations, proposing revisions, and attending Committee meetings. Correspondence should be addressed to:

Secretary, B18 Standards Committee  
The American Society of Mechanical Engineers  
Three Park Avenue  
New York, NY 10016-5990

**Proposing Revisions.** Revisions are made periodically to the Standard to incorporate changes that appear necessary or desirable, as demonstrated by the experience gained from the application of the Standard. Approved revisions will be published periodically.

The Committee welcomes proposals for revisions to this Standard. Such proposals should be as specific as possible, citing the paragraph number(s), the proposed wording, and a detailed description of the reasons for the proposal, including any pertinent documentation.

**Interpretations.** Upon request, the B18 Committee will render an interpretation of any requirement of the Standard. Interpretations can only be rendered in response to a written request sent to the Secretary of the B18 Standards Committee.

The request for interpretation should be clear and unambiguous. It is further recommended that the inquirer submit his/her request in the following format:

Subject: Cite the applicable paragraph number(s) and the topic of the inquiry.  
Edition: Cite the applicable edition of the Standard for which the interpretation is being requested.  
Question: Phrase the question as a request for an interpretation of a specific requirement suitable for general understanding and use, not as a request for an approval of a proprietary design or situation. The inquirer may also include any plans or drawings, which are necessary to explain the question; however, they should not contain proprietary names or information.

Requests that are not in this format may be rewritten in the appropriate format by the Committee prior to being answered, which may inadvertently change the intent of the original request.

ASME procedures provide for reconsideration of any interpretation when or if additional information that might affect an interpretation is available. Further, persons aggrieved by an interpretation may appeal to the cognizant ASME Committee or Subcommittee. ASME does not "approve," "certify," "rate," or "endorse" any item, construction, proprietary device, or activity.

**Attending Committee Meetings.** The B18 Standards Committee regularly holds meetings, which are open to the public. Persons wishing to attend any meeting should contact the Secretary of the B18 Standards Committee.





# METRIC CONTINUOUS AND DOUBLE END STUDS

## 1 INTRODUCTION

### 1.1 Scope

**1.1.1** This standard covers the complete dimensional and general data for continuous thread and double end metric series studs recognized as an American National Standard. The following configurations are covered:

*continuous thread stud*: studs that are threaded over their complete length.

*double end stud (clamping type)*: studs with screw threads of the same length and configuration on each end. This type of stud serves the function of clamping two bodies together with a nut on each end.

*double end stud (tap end type)*: a stud designed to be installed in a tapped hole and usually with different threaded lengths on each end. The tap end studs covered by this standard have the same thread form on each end with the length of the tap end threads equal to approximately  $1\frac{1}{2}$  times the nominal thread diameter.

NOTE: Both types of double end studs in this standard may be installed with a nut on each end. Similarly, one end of each type may be set in a tapped hole, usually with a locking compound.

Double end studs of the following body diameters are covered:

(a) *Reduced Diameter Body*. See para. 6.1 for dimensions.

(b) *Full Body*. See para. 6.2 for dimensions.

**1.1.2** The inclusion of dimensional data in this standard is not intended to imply that all products described are stock production items. Consumers should consult with suppliers concerning availability of products.

## 2 COMPARISON WITH ISO DOCUMENTS

Metric stud standards have not been issued by ISO.

## 3 REFERENCED STANDARDS

The following is a list of publications referenced in this Standard. Unless otherwise specified, the reference shall be to the most recent issue at the time of order placement.

ASME B1.3M, Screw Thread Gaging Systems for Dimensional Acceptability — Inch and Metric Screw Threads (UN, UNR, UNJ, M, and MJ)

ASME B1.13, Metric Screw Threads — M Profile

ASME B18.2.8, Clearance Holes for Bolts, Screws, and Studs

ASME B18.12, Glossary of Terms for Mechanical Fasteners

ASME B18.18.2, Inspection and Quality Assurance for High Volume Machine Assembly Fasteners

ASME B18.24, Part Identifying Number (PIN) Code System Standard for B18 Fastener Products

ASME Y14.5M, Dimensioning and Tolerancing

Publisher: The American Society of Mechanical Engineers (ASME), Three Park Avenue, New York, NY 10016-5990; Order Department: 22 Law Drive, Box 2300, Fairfield, NJ 07007-2300.

ASTM A 380, Standard Practice for Cleaning, Descaling, and Passivation of Stainless Steel Parts, Equipment, and Systems

ASTM F 468M, Nonferrous Bolts, Hex Capscrews, and Studs for General Use

ASTM F 568M, Carbon and Alloy Steel Externally Threaded Metric Fasteners

ASTM F 738M, Stainless Steel Metric Bolts, Screws and Studs

ASTM F 788/F 788M, Surface Discontinuities of Bolts, Screws, and Studs — Inch and Metric Series

ASTM F 1941M, Electrodeposited Coatings on Threaded Fasteners (Metric)

Publisher: ASTM International (ASTM), 100 Barr Harbor Drive, West Conshohocken, PA 19428-2959.

## 4 TERMINOLOGY

For definitions of terms relating to fasteners or features thereof used in this Standard, refer to ASME B18.12.

## 5 DIMENSIONS

(a) All dimensions in this Standard are given in millimeters (mm), and apply before coating, unless stated otherwise. Table 1 contains the dimensions for continuous thread studs. Table 2 contains the dimensions for double end (clamping type) studs. Table 3 contains the dimensions for double end (tap end type) studs. See para. 6 for body diameters on double end studs.

(b) Symbols specifying geometric characteristics are in accord with ASME Y14.5M.

## 6 BODY DIAMETER

The diameter of the body on studs which are not threaded the full length shall be within the limits for  $D_S$  or  $D_R$  as specified for the applicable configuration. Unless otherwise specified by the purchaser, the reduced diameter body or full body may be supplied at the option of the supplier.

### 6.1 Reduced Diameter Body

The body diameter is approximately equal to the pitch diameter of the thread. Reduced diameter body dimensions shall be as specified in Table 4.

### 6.2 Full Body

The maximum body diameter is the basic nominal diameter of the thread. The minimum body diameter is the nominal diameter of the thread minus a tolerance based on the stud length with minimum dimensions as specified in Table 4.

## 7 LENGTH

### 7.1 Overall Length

The overall length,  $L_T$ , of the stud is the distance, parallel to the axis of the stud from one end to the other end, measured to the extreme condition on each end. Tolerances for overall stud lengths are given in Table 5. Overall lengths for continuous thread and clamping type studs (illustrations in Tables 1 and 2) shall be in increments as indicated in applicable tables. For tap end studs (illustration in Table 3), the overall length is not specified but is the sum of the nominal length,  $L$ , and the tap end length,  $B_M$ .

### 7.2 Nominal Length

For continuous and clamping type studs, the nominal length is the same as the overall length without tolerances. For tap end studs (illustration in Table 3), the nominal length,  $L$ , is the protrusion length when the stud is installed. Nominal lengths shall be in increments as indicated in applicable tables.

### 7.3 Length Tolerance

Length tolerances for studs shall be in accordance with Table 5.

## 8 POINTS

Unless otherwise specified, studs with either pointed or unpointed ends may be provided. The ends shall be suitable for marking.

## 8.1 Pointed Ends

Pointed ends shall be chamfered from a diameter equal to or slightly less than the thread root diameter. The length of the point to the first fully formed thread at major diameter, as determined by the distance the point enters into a cylindrical NOT GO major diameter ring gage, shall not exceed  $U_{\max}$ .  $U_{\max}$  is equal to two thread pitches. The ends of the stud shall be reasonably squared with the axis of the stud, but the slight rim or cup resulting from manufacturing shall be permissible.

## 8.2 Unpointed Ends

Unpointed ends may be plain-sheared or cut ends and the slight rim or cup resulting from manufacturing shall be permissible.

## 9 THREAD LENGTH

(a) For continuously threaded studs, the entire length of the stud shall be threaded except for the ends as denoted by dimension  $U$  in the illustration in Table 1.

(b) For double end studs, full threads are required for the lengths  $B_M$  and  $B$  except for the ends as denoted by dimension  $U$  in the illustrations in Tables 2 and 3.

(c) The transition from full thread to incomplete thread shall be smooth and uniform. The major diameter for incomplete threads shall not exceed the actual diameter of the complete (fully formed) threads.

## 10 SCREW THREADS

### 10.1 Thread Series and Tolerance Class

Threads shall be metric coarse thread series tolerance class 6g conforming to the dimensions for general purpose external threads in ASME B1.13M unless otherwise specified by the purchaser. Thread size limits prior to plating or coating shall be class 6g (GO and NOT GO). After plating or coating, class 6g threads shall be accepted using the size limits of 6h GO (high limit) and 6g NOT GO (low limit).

### 10.2 Thread Gaging

Unless otherwise specified, dimensional acceptability of screw threads shall be based on System 21 of ASME B1.3M.

## 11 MATERIALS AND MECHANICAL PROPERTIES

### 11.1 Steel

Unless otherwise specified, steel studs shall conform to the requirements of ASTM F 568M.

### 11.2 Corrosion-Resistant Steels

Unless otherwise specified, studs of corrosion-resistant steels shall conform to the requirements of ASTM F 738M including passivation in accordance with ASTM A 380.

### 11.3 Nonferrous Metals

Unless otherwise specified, nonferrous studs shall conform to the requirements of ASTM F 468M.

## 12 IDENTIFICATION SYMBOLS

Markings shall be located on either the ends or the bodies of the studs unless otherwise specified.

### 12.1 Property Class Symbol

Each stud shall be marked in accordance with the requirements of the applicable specification (see section 11) for its chemical and mechanical requirements. For tap end studs, the material property class symbol shall be marked on the nut end or the body.

### 12.2 Source Symbols

Each stud of a size requiring marking shall be marked to identify its source (manufacturer or private label distributor).

## 13 FINISH

Unless otherwise specified, studs shall be supplied with a natural (as processed) finish, unplated or uncoated, in a clean condition and lightly oiled.

## 14 WORKMANSHIP

Unless otherwise specified, studs shall be free from surface imperfections such as burrs, seams, laps, loose scales, or other irregularities that could affect serviceability. When control of surface discontinuities is required, the purchaser shall specify conformance to ASTM F 788/F 788M.

## 15 STRAIGHTNESS

At maximum material limit, studs must be straight within the limit established by the straightness or camber tolerance value,  $T$ , based on the overall length,  $L_T$ , of the stud as identified below and expressed as a two-place decimal. The referee gage and gaging procedures for checking straightness are provided in Mandatory Appendix I.

(a)  $T = 0.006 L_T$  where  $L_T \leq 600$  mm

(b)  $T = 0.008 L_T$  where  $L_T > 600$  mm

## 16 INSPECTION AND QUALITY ASSURANCE

Studs shall be inspected to determine conformance with this standard. Inspection procedures may be specified by the purchaser on the inquiry, purchase order,

engineering drawings, or shall be as agreed upon between the purchaser and supplier prior to acceptance of the order. In the absence of a defined agreement, the requirements of ASME B18.18.2 shall apply.

## 17 DIMENSIONAL CONFORMANCE

Unless otherwise specified, the following designated dimensional characteristics shall be inspected to the inspection levels shown according to ASME B18.18.2, and shall be within their specified limits:

Characteristic	Inspection Level
Thread acceptability	C
Stud overall length, $L_T$ (not applicable to tap end studs)	C
Stud nominal length, $L$ (tap end studs only)	C
Thread length	C
Straightness	B

If a verifiable, in-process inspection is used, inspection sample sizes and reporting shall be in accordance with the applicable ASME, ASTM, or SAE quality system consensus standard.

## 18 CLEARANCE HOLES

The recommended sizes of clearance holes in material to be assembled using metric studs are those listed in ASME B18.2.8 for metric fasteners.

## 19 DESIGNATION

(a) Studs shall be designated by the following data, preferably in the sequence shown:

- (1) product name
- (2) product standard (ASME B18.31.1M)
- (3) nominal diameter and thread pitch
- (4) nominal length
- (5) steel property class or material identification
- (6) protective coating, if required

EXAMPLES:

- (1) Continuous thread stud, ASME B18.31.1M, M20 × 2.5 × 50, ASTM F 568M Class 8.8, zinc-plated per ASTM F 1941M Classification Code Fe/Zn 5A.
- (2) Clamping type stud, reduced diameter body, ASME B18.31.1M, M10 × 1.5 × 60, ASTM F 468M nickel-copper alloy 400.
- (3) Tap end stud, full body, ASME B18.31.1M, M16 × 2 × 100, ASTM F 738M Class A4-70.

(b) Optionally, studs may be designated by a Part Identifying Number when defined in ASME B18.24.

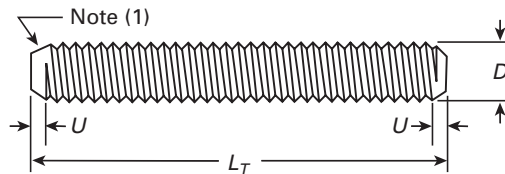

**Table 1 Dimensions for Continuous Thread Studs**

Nominal Size		$U_{max} = 2P$	Nominal Length, $L_T$ [Note (2)]	
Diameter, $D$	Pitch, $P$		Range	Increments
M5	0.8	1.6	12–20	4
			25–50	5
			60–160	10
			$\geq 180$	20
M6	1	2.0	16–20	4
			25–50	5
			60–160	10
			$\geq 180$	20
M8	1.25	2.5	25–50	5
			60–160	10
			$\geq 180$	20
			30–50	5
M10	1.5	3.0	60–160	10
			$\geq 180$	20
			40–50	5
			60–160	10
M12	1.75	3.5	$\geq 180$	20
			60–160	10
			$\geq 180$	20
			60–160	10
M14 [Note (3)]	2	4.0	$\geq 180$	20
			60–160	10
			$\geq 180$	20
			60–160	10
M16	2	4.0	$\geq 180$	20
			60–160	10
			$\geq 180$	20
			60–160	10
M20	2.5	5.0	60–160	10
			$\geq 180$	20
			60–160	10
			$\geq 180$	20
M22	2.5	5.0	60–160	10
			$\geq 180$	20
			70–160	10
			$\geq 180$	20
M24	3	6.0	80–160	10
			$\geq 180$	20
			90–160	10
			$\geq 180$	20
M27	3	6.0	110–160	10
			$\geq 180$	20
			120–160	10
			$\geq 180$	20
M30	3.5	7.0	150–160	10
			$\geq 180$	20
			110–160	10
			$\geq 180$	20
M36	4	8.0	120–160	10
			$\geq 180$	20
			120–160	10
			$\geq 180$	20
M42	4.5	9.0	150–160	10
			$\geq 180$	20
			150–160	10
			$\geq 180$	20
M48	5	10.0	$\geq 180$	20
			150–160	10
			$\geq 180$	20
			150–160	10
M56	5.5	11.0	$\geq 180$	20
			150–160	10
			$\geq 180$	20
			150–160	10
M64	6	12.0	$\geq 180$	20
			150–160	10
			$\geq 180$	20
			150–160	10
M72, M80, M90 and M100	6	12.0	$\geq 200$	20
			150–160	10
			$\geq 180$	20
			150–160	10

GENERAL NOTE: All dimensions are in millimeters unless otherwise indicated.

NOTES:

- (1) See section 8 for end requirements.
- (2) See Table 5 for tolerances on stud lengths.
- (3) A nonpreferred size; not recommended for new design due to limited availability.

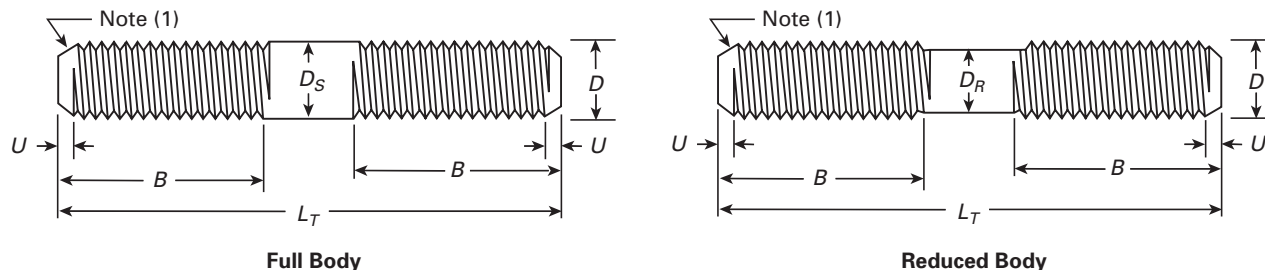

**Table 2 Dimensions for Clamping Type Studs**

Nominal Size		Thread Length, <i>B</i> [Note (2)]						$U_{max} = 2P$	Nominal Length, $L_T$ [Note (3)]	
Diameter, <i>D</i> [Note (4)]	Pitch, <i>P</i>	$L_T \leq 250$		$250 < L_T \leq 400$		$L_T > 400$			Range	Increments
		Min.	Max.	Min.	Max.	Min.	Max.			
M1.6	0.35	9.2	9.9	...	...	...	...	0.7	25-50	5
M2	0.4	10	10.8	...	...	...	...	0.8	25-50	5
M2.5	0.45	11	11.9	...	...	...	...	0.9	30-50	5
M3	0.5	12	13	...	...	...	...	1	30-50	5
M4	0.7	14	15.4	...	...	...	...	1.4	35-90	5
M5	0.8	16	17.6	...	...	...	...	1.6	40-90	5
M6	1	18	20	24	26	...	...	2	50-90	5
M8	1.25	18	20.5	24	26.5	...	...	2.5	100-160	10
									50-90	5
									100-160	10
									$\geq 180$	20
M10	1.5	26	29	32	35	45	48	3	60-160	10
									$\geq 180$	20
M12	1.75	30	33.5	36	39.5	49	52.5	3.5	60-160	10
									$\geq 180$	20
M14 [Note (5)]	2	34	38	40	44	53	57	4	80-160	10
									$\geq 180$	20
M16	2	38	42	44	48	57	61	4	90-160	10
									$\geq 180$	20
M20	2.5	46	51	52	57	65	70	5	100-160	10
									$\geq 180$	20
M24	3	54	60	60	66	73	79	6	130-160	10
									$\geq 180$	20
M30	3.5	66	73	72	79	85	92	7	150-160	10
									$\geq 180$	20
M36	4	78	86	84	92	97	105	8	$\geq 200$	20
M42	4.5	90	99	96	105	109	118	9	$\geq 240$	20
M48	5	...	...	108	118	121	131	10	$\geq 280$	20
M56	5.5	...	...	124	135	137	148	11	$\geq 300$	20
M64	6	...	...	140	152	153	165	12	$\geq 340$	20
M72	6	...	...	156	168	169	181	12	$\geq 380$	20
M80	6	...	...	172	184	185	197	12	$\geq 400$	20
M90	6	...	...	...	...	205	217	12	$\geq 440$	20
M100	6	...	...	...	...	225	237	12	$\geq 480$	20

GENERAL NOTE: All dimensions are in millimeters unless otherwise indicated.

NOTES:

- (1) See section 8 for end requirements.
- (2) The nominal thread length is equal to  $B_{min}$ . The maximum thread length is the minimum thread length (nominal length) plus a value equal to two thread pitches.
- (3) See Table 5 for tolerances on stud lengths.
- (4) See Table 4 for body diameters for full body or reduced body studs.
- (5) A nonpreferred size; not recommended for new design due to limited availability.

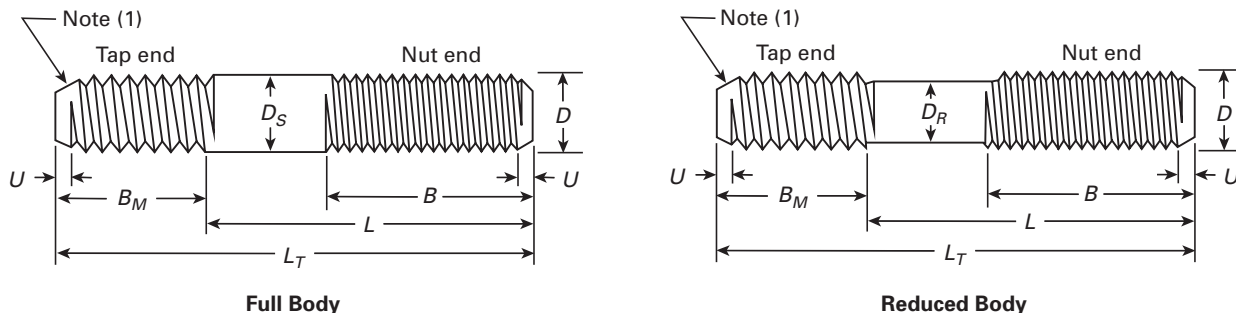

**Table 3 Dimensions for Tap End Studs (1.5D Engagement)**

Nominal Size		Tap End Length, $B_M$	Nut End Thread Length, $B$ [Note (2)]						$U_{max} = 2P$	Nominal Length, $L$ [Note (3)]	
Diameter, $D$ [Note (4)]	Pitch, $P$		$L \leq 125$		$125 < L \leq 200$		$L > 200$			Range	Increments
			Min.	Max.	Min.	Max.	Min.	Max.			
M1.6	0.35	2.1–2.7	9.2	9.9	...	...	...	...	0.7	25–50	5
M2	0.4	2.7–3.3	10	10.8	...	...	...	...	0.8	25–50	5
M2.5	0.45	3.375–4.125	11	11.9	...	...	...	...	0.9	30–50	5
M3	0.5	4.125–4.875	12	13	...	...	...	...	1	30–50	5
M4	0.7	5.625–6.375	14	15.4	...	...	...	...	1.4	35–90	5
M5	0.8	7.05–7.95	16	17.6	...	...	...	...	1.6	40–90	5
M6	1	8.55–9.45	18	20	24	26	...	...	2	50–90	5
M8	1.25	11.45–12.55	18	20.5	24	26.5	...	...	2.5	50–90	5
										100–160	10
										≥ 180	20
M10	1.5	14.45–15.55	26	29	32	35	45	48	3	60–160	10
M12	1.75	17.45–18.55	30	33.5	36	39.5	49	52.5	3.5	60–160	10
										≥ 180	20
M14 [Note (5)]	2	20.35–21.65	34	38	40	44	53	57	4	80–160	10
										≥ 180	20
M16	2	23.35–30.65	38	42	44	48	57	61	4	90–160	10
										≥ 180	20
M20	2.5	29.35–30.65	46	56	52	57	65	70	5	100–160	10
										≥ 180	20
M24	3	35.2–36.8	54	60	60	66	73	79	6	130–160	10
										≥ 180	20
M30	3.5	43.75–46.25	66	73	72	79	85	92	7	150–160	10
										≥ 180	20
M36	4	52.5–55.5	78	86	84	92	97	105	8	≥ 200	20
M42	4.5	61.5–64.5	90	99	96	105	109	118	9	≥ 240	20
M48	5	70.5–73.5	...	...	108	118	121	131	10	≥ 280	20
M56	5.5	82.25–85.75	...	...	124	135	137	148	11	≥ 300	20
M64	6	94.5–97.5	...	...	140	152	153	165	12	≥ 340	20
M72	6	106.5–109.5	...	...	156	168	169	181	12	≥ 380	20
M80	6	118.5–121.5	...	...	172	184	185	197	12	≥ 400	20
M90	6	133–137	...	...	...	...	205	217	12	≥ 440	20
M100	6	148–152	...	...	...	...	225	237	12	≥ 480	20

GENERAL NOTE: All dimensions are in millimeters unless otherwise indicated.

NOTES:

- (1) See section 8 for end requirements.
- (2) The nominal thread length is equal to  $B_{min}$ . The maximum thread length is the minimum thread length (nominal length) plus a value equal to two thread pitches.
- (3) See Table 5 for tolerances on stud lengths.
- (4) See Table 4 for body diameters for full body or reduced body studs.
- (5) A nonpreferred size; not recommended for new design due to limited availability.

**Table 4 Body Dimensions for Double End Studs**

Nominal Size		Body Diameter, $D_R$ , for Reduced Body Studs			Body Diameter, $D_S$ , for Full Body Studs		
		Maximum Overall Length, $L_T$		Minimum	Maximum	Minimum Overall Length, $L_T$	
Diameter, $D$	Pitch, $P$	$\leq 150$	$> 150$			$\leq 150$	$> 150$
M1.6	0.35	...	...	...	1.60	1.29	1.29
M2	0.4	...	...	...	2.00	1.65	1.65
M2.5	0.45	...	...	...	2.50	2.12	2.12
M3	0.5	...	...	...	3.00	2.58	2.58
M4	0.7	...	...	...	4.00	3.43	3.43
M5	0.8	...	...	...	5.00	4.36	4.36
M6	1	5.39	5.51	5.21	6.00	5.82	5.70
M8	1.25	7.26	7.40	7.04	8.00	7.78	7.64
M10	1.5	9.08	9.22	8.86	10.00	9.78	9.64
M12	1.75	10.95	11.11	10.68	12.00	11.73	11.57
M14 [Note (1)]	2	12.77	12.93	12.50	14.00	13.73	13.57
M16	2	14.77	14.93	14.50	16.00	15.73	15.57
M20	2.5	18.49	18.68	18.16	20.00	19.67	19.48
M24	3	22.13	22.32	21.80	24.00	23.67	23.48
M30	3.5	...	27.98	27.46	30.00	...	29.48
M36	4	...	33.74	33.12	36.00	...	35.38
M42	4.5	...	39.40	38.78	42.00	...	41.38
M48	5	...	45.05	44.43	48.00	...	47.38
M56	5.5	...	52.83	52.09	56.00	...	55.26
M64	6	...	60.48	59.74	64.00	...	63.26
M72	6	...	68.48	67.74	72.00	...	71.26
M80	6	...	76.48	75.74	80.00	...	79.26
M90	6	...	86.61	85.74	90.00	...	89.13
M100	6	...	96.59	95.72	100.00	...	99.13

GENERAL NOTE: All dimensions are in millimeters unless otherwise indicated.

NOTE:

(1) A nonpreferred size; not recommended for new design due to limited availability.

**Table 5 Length Tolerances —  
 $L_T$  for Continuous Thread and Clamping Type Studs, and  $L$  for Tap End Studs**

Nominal Length [Note (1)]		Length Tolerance	
		Clamping Type and Tap End Studs	Continuous Thread Studs
Over	Through		
6	10	$\pm 0.29$	$\pm 0.45$
10	18	$\pm 0.35$	$\pm 0.55$
18	30	$\pm 0.42$	$\pm 0.65$
30	50	$\pm 0.50$	$\pm 0.80$
50	80	$\pm 0.95$	$\pm 1.50$
80	120	$\pm 1.10$	$\pm 1.75$
120	180	$\pm 1.25$	$\pm 2.00$
180	250	$\pm 1.45$	$\pm 2.30$
250	315	$\pm 1.60$	$\pm 2.60$
315	400	$\pm 1.80$	$\pm 2.85$
400	500	$\pm 2.00$	$\pm 3.15$
>500	...	$\pm 5.00$	$\pm 10.00$

GENERAL NOTE: All dimensions are in millimeters unless otherwise indicated.

NOTE:

(1) Nominal length is  $L_T$  for continuous thread and clamping type studs, and  $L$  for tap end studs.



## MANDATORY APPENDIX I STUD STRAIGHTNESS, REFEREE GAGE, AND GAGING PROCEDURES

The conformance of stud straightness or camber limitations set forth in the product standards shall be checked using the gage illustrated in Fig. I-1, in accordance with the following procedure:

Allowable total camber on the stud to be inspected shall be calculated in accordance with the product standard by multiplying the specified permissible camber by the overall length of the stud and expressing the result as a two-place decimal. The total camber thus calculated shall be added to the specified maximum body or major thread diameters, whichever is larger, and the adjustable rail of gage shall be adjusted to provide a

parallel space between the rails equal to this distance by obtaining common readings on both micrometer heads. The adjustable rail shall then be locked in place by tightening securing screws.

The stud shall then be placed between the rails so that a length not to exceed one nominal diameter extends out of the gage. The stud shall be considered acceptable for straightness if it can be rotated a full 360 deg by hand. Any interference occurring between the stud and gage that is sufficient to prevent rotation shall indicate excessive camber.

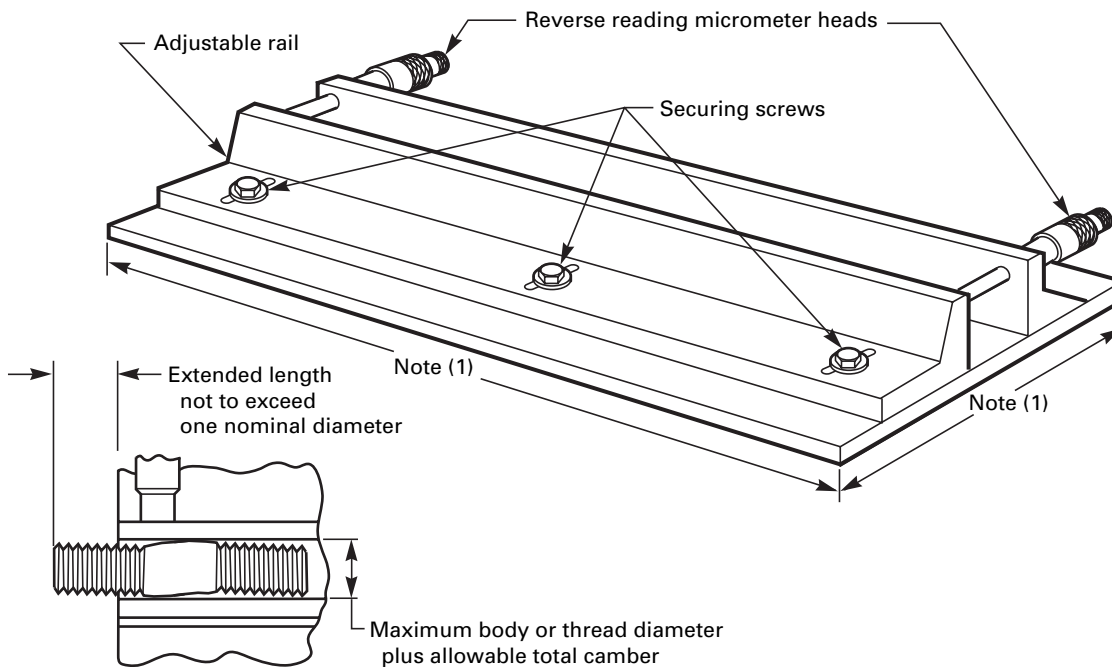

**NOTE:**

(1) Gage must be of sufficient width and length to accommodate the diameter and entire length of the stud being gaged.

**Fig. I-1 Typical Straightness Gage**

# ASME B18.31.1M-2005

ISBN 0-7918-2974-X



9 780791 829745



M18905