

**ASME B18.2.6-2019**  
(Revision of ASME B18.2.6-2010)

# **Fasteners for Use in Structural Applications**

---

**AN AMERICAN NATIONAL STANDARD**



**The American Society of  
Mechanical Engineers**

**ASME B18.2.6-2019**  
(Revision of ASME B18.2.6-2010)

# **Fasteners for Use in Structural Applications**

---

**AN AMERICAN NATIONAL STANDARD**



**The American Society of  
Mechanical Engineers**

Two Park Avenue • New York, NY • 10016 USA

Date of Issuance: March 29, 2019

This Standard will be revised when the Society approves the issuance of a new edition.

ASME issues written replies to inquiries concerning interpretations of technical aspects of this Standard. Interpretations are published on the Committee web page and under <http://go.asme.org/InterpsDatabase>. Periodically certain actions of the ASME B18 Committee may be published as Cases. Cases are published on the ASME website under the B18 Committee Page at <http://go.asme.org/B18committee> as they are issued.

Errata to codes and standards may be posted on the ASME website under the Committee Pages to provide corrections to incorrectly published items, or to correct typographical or grammatical errors in codes and standards. Such errata shall be used on the date posted.

The B18 Committee Page can be found at <http://go.asme.org/B18committee>. There is an option available to automatically receive an e-mail notification when errata are posted to a particular code or standard. This option can be found on the appropriate Committee Page after selecting "Errata" in the "Publication Information" section.

ASME is the registered trademark of The American Society of Mechanical Engineers.

This code or standard was developed under procedures accredited as meeting the criteria for American National Standards. The Standards Committee that approved the code or standard was balanced to assure that individuals from competent and concerned interests have had an opportunity to participate. The proposed code or standard was made available for public review and comment that provides an opportunity for additional public input from industry, academia, regulatory agencies, and the public-at-large.

ASME does not "approve," "rate," or "endorse" any item, construction, proprietary device, or activity.

ASME does not take any position with respect to the validity of any patent rights asserted in connection with any items mentioned in this document, and does not undertake to insure anyone utilizing a standard against liability for infringement of any applicable letters patent, nor assume any such liability. Users of a code or standard are expressly advised that determination of the validity of any such patent rights, and the risk of infringement of such rights, is entirely their own responsibility.

Participation by federal agency representative(s) or person(s) affiliated with industry is not to be interpreted as government or industry endorsement of this code or standard.

ASME accepts responsibility for only those interpretations of this document issued in accordance with the established ASME procedures and policies, which precludes the issuance of interpretations by individuals.

No part of this document may be reproduced in any form,  
in an electronic retrieval system or otherwise,  
without the prior written permission of the publisher.

The American Society of Mechanical Engineers  
Two Park Avenue, New York, NY 10016-5990

Copyright © 2019 by  
THE AMERICAN SOCIETY OF MECHANICAL ENGINEERS  
All rights reserved  
Printed in U.S.A.

# CONTENTS

Foreword .....	iv
Committee Roster .....	vii
Correspondence With the B18 Committee .....	viii
<b>1</b> <b>Introductory Notes .....</b>	<b>1</b>
<b>2</b> <b>Heavy Hex Structural Bolts: ASTM F3125/F3125M .....</b>	<b>2</b>
<b>3</b> <b>Heavy Hex Nuts: ASTM A563 and ASTM A194/A194M .....</b>	<b>6</b>
<b>4</b> <b>Hardened Steel Washers: ASTM F436/F436M .....</b>	<b>8</b>
<b>5</b> <b>Compressible Washer-Type Direct Tension Indicators: ASTM F959/F959M .....</b>	<b>11</b>
<b>6</b> <b>Twist-Off-Type Structural Bolts, Heavy Hex and Round: ASTM F3125/F3125M .....</b>	<b>13</b>
<b>Figure</b>	
6.8.1-1      Groove Diameter .....	15
<b>Tables</b>	
2.1-1      Dimensions of Heavy Hex Structural Bolts .....	3
2.1.9.2-1      Maximum Grip Gaging Lengths and Minimum Body Lengths for Structural Bolts .....	5
3.1-1      Dimensions of Heavy Hex Nuts for Use With Structural Bolts .....	7
4.1.1-1      Dimensions for Hardened Steel Circular and Circular Clipped Washers .....	9
4.2.1-1      Dimensions of Hardened Beveled Washers With Slope or Taper in Thickness 1:6 .....	10
5.1-1      Dimensions for Compressible Washer-Type Direct Tension Indicators .....	12
6.1.1-1      Dimensions of Twist-Off-Type Structural Bolts: Heavy Hex Head and Round Head Configurations	14

# FOREWORD

The B18 Standards Committee for the standardization of bolts, screws, nuts, rivets, and similar fasteners was organized in March 1922 as the B18 Sectional Committee under the aegis of the American Engineering Standards Committee [later the American Standards Association, then the United States of America Standards Institute and, as of October 6, 1969, the American National Standards Institute, Inc. (ANSI)], with the Society of Automotive Engineers and the American Society of Mechanical Engineers as joint sponsors. B18 Subcommittee 2 was subsequently established and charged with the responsibility for technical content of standards covering wrench head bolts and nuts.

Subcommittee 2, after appraisal of the requirements of industry, developed a proposed standard series of bolt head and nut dimensions. This proposal was finally approved and designated a Tentative American Standard in February 1927.

A first revision of the document was designated as an American Standard in March 1933 and was followed by a second revision, which was granted approval as an American Standard in January 1941.

Following reorganization of the B18 Committee in 1947, Subcommittee 2 was asked to expand the Standard on head proportions into a complete product standard. A proposal covering square and hexagon head bolts and nuts, hexagon head cap screws, and automotive hexagon head bolts was prepared and submitted to the B18 Committee in April 1950. While this draft was under consideration, the B18 Committee received a proposal from the British Standards Institution for unification of dimensions on products incorporating unified screw threads. The Committee welcomed the opportunity of discussing the proposals and an American-British-Canadian conference was held in New York, June 1 and 2, 1950.

It was agreed in the conference that the essentials of unification could be accomplished by selection of mutually satisfactory across-the-flats dimensions, since this would permit the use of the same wrenches and because other features would rarely affect interchangeability. After due consideration, suitable existing across-the-flats dimensions were selected for the hexagon products.

In its meeting on October 13, 1950, Subcommittee 2 agreed to incorporate in the proposed standard the conference recommendations on  $\frac{1}{4}$ -in. hexagon head bolts,  $\frac{5}{8}$ -in. hexagon head cap screws and automotive hexagon head bolts,  $\frac{5}{16}$ -in. and  $\frac{3}{8}$ -in. regular hexagon and square nuts, and  $\frac{7}{16}$ -in. light and regular hexagon and square nuts. At a subsequent meeting of Subcommittee 2, further changes were adopted in order to combine the light and regular series of nuts and to combine the automotive hexagon head bolt, hexagon head cap screw, and regular hexagon head close tolerance bolt.

In view of the progress made in the United States and the urgency of standardization for mutual defense, the British Standards Institution sponsored a second conference in London in April 1951 to complete the unification of certain hexagon bolts and nuts.

At a meeting on June 8, 1951, Subcommittee 2 reaffirmed its acceptance of the unified dimensions, which corresponded with those in the March 1951 draft, but attempted to select better nomenclature for the unified products. A final draft incorporating the nomenclature *Finished Hexagon Bolts and Nuts* and numerous editorial changes was submitted for letter ballot in September 1951. Following approval by the B18 Committee and the sponsors, the proposal was presented to the American Standards Association for approval and designation as an American Standard. This was granted on March 24, 1952.

Recognizing the Standard was in need of additional refinements, Subcommittee 2 began immediately to revise it by removing inconsistencies with respect to fillets, improving the length tolerances on heavy hexagon bolts, and incorporating numerous other corrections and clarifications. The most noteworthy editorial change was a decision to combine the coverage for hexagon cap screws and square-head set screws from the B18.2 Standard with the coverage for slotted-head cap screws and slotted headless set screws from the B18.6 Standard and publish them in a separate document. The requirements for the unified hexagon cap screws and finished hexagon bolts being identical in the overlapping sizes, this data would now be available in two publications. Following approvals by the B18 Committee and sponsor organizations, the proposal was submitted to the American Standards Association and declared an American Standard on February 2, 1955.

A revision of this document comprised of numerous editorial corrections and inclusions of an appendix for grade markings was duly approved and designated an American Standard on April 18, 1960.

At a meeting in February 1960, Subcommittee 2 approved a recommendation to reduce the head heights for heavy, heavy semifinished, and heavy finished hexagon bolts which were subsequently approved by letter ballot of the B18 Committee on August 16, 1960. A proposed standard for heavy hexagon structural bolts submitted and accepted by Subcommittee 2 at its October 17, 1960, meeting was approved by letter ballot of the B18 Committee on May 9, 1961. To

meet the urgent needs of the steel construction industry, it was considered necessary to publish the Standard for the structural bolts immediately. Consequently, Appendix IV to ASA B18.2-1960 containing coverage for the revised heavy hexagon bolts and the new heavy hexagon structural bolts was released in 1962.

In October 1961, Subcommittee 2 appointed a subgroup to review all product standards for square and hexagon bolts, screws, and nuts, and to recommend simplifications that would be compatible with technical, production, and distribution advances that had occurred over the previous several years. The subgroup presented its recommendations at a meeting of Subcommittee 2 in October 1962. It was agreed that the internally and externally threaded products should be published in separate documents as suggested, and draft proposals for each were completed.

The proposed revision for square and hex bolts, and screws incorporated the following subgroup recommendations: consolidation of hexagon head cap screws and finished hexagon bolts into a single product, consolidation of heavy semifinished hexagon bolts and heavy finished hexagon bolts into a single product, elimination of regular semifinished hexagon bolts, new length tolerancing values for all bolts and screws, documentation of a positive identification procedure for determining whether an externally threaded product should properly be designated a bolt or a screw, and an abbreviated and purified set of product nomenclature reflecting application of the identification procedure. Letter ballot of this proposal to the B18 Committee in March 1964 resulted in several comments, which were resolved to the satisfaction of the Committee in June 1964. Following acceptance by the sponsor organizations, the revision was submitted to the American Standards Association and was designated American Standard ASA B18.2.1 on September 8, 1965.

In 1992, Subcommittee 2 recognized the value of having all structural products in a single standard. In a revision initiated for the B18.2.1 Standard in that year, it was proposed to remove the heavy hex structural bolt from the B18.2.1 Standard, the heavy hex nut from the B18.2.2 Standard, and combine these with the dimensions of hardened steel washers from ASTM F436 and the compressible-washer-type direct tension indicator dimensions of ASTM F959. This new Standard would then provide all standardized dimensions for the fasteners intended for use in structural applications. The first draft of this Standard was submitted to Subcommittee 2 at its May 1993 meeting. It was subsequently approved as an American National Standard on December 4, 1996.

In December 2008, the B18.2 Subcommittee agreed to begin the updating of ASME B18.2.6. The document's format was revised to meet the new guidelines for B18 Standards. The inside diameters of the hardened washer were revised to match the revised size indicated in ASTM F436. An alternative design for the  $\frac{5}{8}$ -in. size compressible-washer-type direct tension indicator was introduced to simplify production tooling for some washer manufacturers. References to platings and coatings in the various product sections were removed and the users of this Standard are directed to the appropriate ASTM material standard to determine finish requirements in addition to other physical and mechanical properties. The quality assurance section was simplified by removing the reference to ASME B18.18.1 and the list of designated inspection characteristics. Instead, users are directed to ASME B18.18 for the quality assurance requirements and sampling plans for all product characteristics.

The revision of [para. 2.1.6](#), Bearing Surface, was the final resolved issue. It was learned that a significant amount of ASTM A325 and ASTM A490 bolts have always been produced by the hot heading method, which leaves a die seam across the bolt-bearing surface. A sentence was added to the section specifically stating that die seams are permissible. Even though no problems had ever been reported relative to the presence of the die seams, one concerned party raised an objection to the addition of this statement. It was decided that this issue should be resolved by conducting a testing program to objectively determine if die seams on structural bolt-bearing surfaces cause any detrimental performance in application. Several lots of ASTM A325 and ASTM A490 bolts were tested in an ISO 17025 accredited laboratory. Bolts and nuts were assembled in tension-testing equipment with the tightening torque applied through the rotation of the nut in one set of lots and then by rotating the bolts by their heads in another series of lots. An 88-page report was created, including details on the testing of all lots, bolt chemical and physical certificates, photographs of each stage of testing, and the accreditation certificate for the testing laboratory. The report was submitted to Professor Emeritus Dr. John Fisher of Lehigh University for review and comment. In his conclusion, Dr. Fisher stated, "Hence I do not see any reason to consider the installation of bolts with or without seams to differ in achieving the desired preload thereby providing the desired slip resistance. The torque variability is consistent with past studies. Seams are not a significant factor as demonstrated by this study." The Standard was published containing the statement permitting die seams on structural bolt-bearing surfaces. The 2010 edition was approved by ANSI on July 8, 2010.

In May 2015, the Subcommittee elected to include flatness criteria for the tops of bolt heads, which in practice may be formed with a slight convex or concave surface to aid forming. In this edition, [para. 2.1.4](#) has been revised accordingly. [Section 5](#) on direct tension indicators has been revised to accommodate updates to ASTM F959/F959M, including a reduced minimum outer diameter and the common requirement of a minimum of four protrusions regardless of type. Revisions to the inside diameter have been incorporated as well. The release of ASTM F3125/F3125M consolidated the structural bolting standards of ASTM A325/A325M, ASTM A490/A490M, ASTM F1852, and ASTM F2280, and required updating of references throughout this Standard. It also reintroduced requirements for 1¼-in. twist-off-type structural

bolts, and those dimensions have been reinstated in this Standard. Further revisions include dropping the terminology of *tension control* and restructuring of the section on twist-off-type bolts to be consistent with the section on heavy hex bolts.

This edition was approved by ANSI on February 27, 2019.

# ASME B18 COMMITTEE

## Standardization of Bolts, Nuts, Rivets, Screws, Washers, and Similar Fasteners

(The following is the roster of the Committee at the time of approval of this Standard.)

### STANDARDS COMMITTEE OFFICERS

**W. Guth**, *Chair*  
**J. Medcalf**, *Vice Chair*  
**L. Chan**, *Secretary*

### STANDARDS COMMITTEE PERSONNEL

<b>T. Anderson</b> , Bay Bolt	<b>C. B. Williamson</b> , Fastenal Co.
<b>L. Borowski</b> , Greenslade & Co., Inc.	<b>C. J. Wilson</b> , Consultant
<b>S. Brahim</b> , Industrial Fasteners Institute	<b>J. F. McCarrick</b> , <i>Alternate</i> , Defense Supply Center — Philadelphia
<b>B. Cao</b> , Infasco	<b>M. Byrne</b> , <i>Contributing Member</i> , General Fasteners Co.
<b>V. Cartina</b> , Hi-Performance Fastening Systems	<b>D. A. Clever</b> , <i>Contributing Member</i> , Consultant
<b>L. Chan</b> , The American Society of Mechanical Engineers	<b>R. W. Davidson</b> , <i>Contributing Member</i> , Endries International
<b>L. Claus</b> , NNI Training and Consulting, Inc.	<b>J. J. Grey</b> , <i>Contributing Member</i> , Fastener Consulting Services, Inc.
<b>A. P. Cockman</b> , Consultant	<b>J. C. Jennings</b> , <i>Contributing Member</i> , Naval Surface Warfare Center — Philadelphia
<b>C. K. Cooney</b> , The Yorkshire Group, LLC	<b>M. Kaindl</b> , <i>Contributing Member</i> , Aztech Locknut Co.
<b>D. S. George</b> , Michigan Metal Coating	<b>D. Korneffel</b> , <i>Contributing Member</i> , Cadenas PARTsolutions
<b>W. Guth</b> , Electric Boat Corp.	<b>M. D. Prasad</b> , <i>Contributing Member</i> , Global M & F Solutions, Inc.
<b>B. P. Lowry</b> , Curtis Metal Finishing	<b>J. J. Stoczanskyj</b> , <i>Contributing Member</i> , Beacon Fasteners and Components, Inc.
<b>J. Medcalf</b> , Field Fastener	<b>R. D. Strong</b> , <i>Contributing Member</i> , Lear Corp.
<b>M. Q. Muhammad</b> , Defense Logistics Agency — Troop Support	<b>C. G. Vertullo</b> , <i>Contributing Member</i> , Carver Engineering and Manufacturing
<b>J. P. Nash</b> , Caterpillar, Inc.	
<b>F. J. Perry</b> , John Deere	
<b>D. F. Sharp</b> , TurnaSure, LLC	

### SUBCOMMITTEE 2 — EXTERNALLY DRIVEN FASTENERS

<b>J. P. Nash</b> , <i>Chair</i> , Caterpillar, Inc.	<b>J. Richardson</b> , Applied Bolting Technology
<b>T. Anderson</b> , Bay Bolt	<b>D. F. Sharp</b> , TurnaSure, LLC
<b>L. Borowski</b> , Greenslade & Co., Inc.	<b>S. E. Shivak</b> , Ramco Specialties
<b>S. Brahim</b> , Industrial Fasteners Institute	<b>G. M. Simpson</b> , Semblex Corp.
<b>B. Cao</b> , Infasco	<b>Q. M. Smith III</b> , Faurecia
<b>V. Cartina</b> , Hi-Performance Fastening Systems	<b>J. J. Stoczanskyj</b> , Beacon Fasteners and Components, Inc.
<b>L. Claus</b> , NNI Training and Consulting, Inc.	<b>C. J. Wilson</b> , Consultant
<b>A. P. Cockman</b> , Consultant	<b>D. Winn</b> , Kamax
<b>J. E. Dutton</b> , Allengheny Coatings	<b>H. T. Winslow II</b> , Newport News Shipbuilding
<b>M. C. Friel</b> , Haydon Bolts, Inc.	<b>J. F. McCarrick</b> , <i>Alternate</i> , Defense Supply Center — Philadelphia
<b>D. S. George</b> , Michigan Metal Coating	<b>D. A. Clever</b> , <i>Contributing Member</i> , Consultant
<b>W. Guth</b> , Electric Boat Corp.	<b>J. S. Foote</b> , <i>Contributing Member</i> , Trade Association Management, Inc.
<b>R. A. Lund</b> , Fastenal Co.	<b>J. C. Jennings</b> , <i>Contributing Member</i> , Naval Surface Warfare Center — Philadelphia
<b>J. Medcalf</b> , Field Fastener	<b>R. D. Strong</b> , <i>Contributing Member</i> , Lear Corp.
<b>M. Q. Muhammad</b> , Defense Logistics Agency — Troop Support	
<b>F. J. Perry</b> , John Deere	



# CORRESPONDENCE WITH THE B18 COMMITTEE

**General.** ASME Standards are developed and maintained with the intent to represent the consensus of concerned interests. As such, users of this Standard may interact with the Committee by requesting interpretations, proposing revisions or a case, and attending Committee meetings. Correspondence should be addressed to:

Secretary, B18 Standards Committee  
The American Society of Mechanical Engineers  
Two Park Avenue  
New York, NY 10016-5990  
<http://go.asme.org/Inquiry>

**Proposing Revisions.** Revisions are made periodically to the Standard to incorporate changes that appear necessary or desirable, as demonstrated by the experience gained from the application of the Standard. Approved revisions will be published periodically.

The Committee welcomes proposals for revisions to this Standard. Such proposals should be as specific as possible, citing the paragraph number(s), the proposed wording, and a detailed description of the reasons for the proposal, including any pertinent documentation.

**Proposing a Case.** Cases may be issued to provide alternative rules when justified, to permit early implementation of an approved revision when the need is urgent, or to provide rules not covered by existing provisions. Cases are effective immediately upon ASME approval and shall be posted on the ASME Committee web page.

Requests for Cases shall provide a Statement of Need and Background Information. The request should identify the Standard and the paragraph, figure, or table number(s), and be written as a Question and Reply in the same format as existing Cases. Requests for Cases should also indicate the applicable edition(s) of the Standard to which the proposed Case applies.

**Interpretations.** Upon request, the B18 Standards Committee will render an interpretation of any requirement of the Standard. Interpretations can only be rendered in response to a written request sent to the Secretary of the B18 Standards Committee.

Requests for interpretation should preferably be submitted through the online Interpretation Submittal Form. The form is accessible at <http://go.asme.org/InterpretationRequest>. Upon submittal of the form, the Inquirer will receive an automatic e-mail confirming receipt.

If the Inquirer is unable to use the online form, he/she may mail the request to the Secretary of the B18 Standards Committee at the above address. The request for an interpretation should be clear and unambiguous. It is further recommended that the Inquirer submit his/her request in the following format:

- Subject: Cite the applicable paragraph number(s) and the topic of the inquiry in one or two words.
- Edition: Cite the applicable edition of the Standard for which the interpretation is being requested.
- Question: Phrase the question as a request for an interpretation of a specific requirement suitable for general understanding and use, not as a request for an approval of a proprietary design or situation. Please provide a condensed and precise question, composed in such a way that a “yes” or “no” reply is acceptable.
- Proposed Reply(ies): Provide a proposed reply(ies) in the form of “Yes” or “No,” with explanation as needed. If entering replies to more than one question, please number the questions and replies.
- Background Information: Provide the Committee with any background information that will assist the Committee in understanding the inquiry. The Inquirer may also include any plans or drawings that are necessary to explain the question; however, they should not contain proprietary names or information.

Requests that are not in the format described above may be rewritten in the appropriate format by the Committee prior to being answered, which may inadvertently change the intent of the original request.

Moreover, ASME does not act as a consultant for specific engineering problems or for the general application or understanding of the Standard requirements. If, based on the inquiry information submitted, it is the opinion of the Committee that the Inquirer should seek assistance, the inquiry will be returned with the recommendation that such assistance be obtained.

ASME procedures provide for reconsideration of any interpretation when or if additional information that might affect an interpretation is available. Further, persons aggrieved by an interpretation may appeal to the cognizant ASME Committee or Subcommittee. ASME does not “approve,” “certify,” “rate,” or “endorse” any item, construction, proprietary device, or activity.

**Attending Committee Meetings.** The B18 Standards Committee regularly holds meetings and/or telephone conferences that are open to the public. Persons wishing to attend any meeting and/or telephone conference should contact the Secretary of the B18 Standards Committee. Future Committee meeting dates and locations can be found on the Committee Page at <http://go.asme.org/B18committee>.

INTENTIONALLY LEFT BLANK

# FASTENERS FOR USE IN STRUCTURAL APPLICATIONS

## 1 INTRODUCTORY NOTES

### 1.1 Scope

**1.1.1** This Standard covers the complete general and dimensional data for five products in the inch series recognized as an American National Standard. These five structural products include

- (a) heavy hex structural bolts: ASTM F3125/F3125M
- (b) heavy hex nuts: ASTM A563 and ASTM A194/A194M
- (c) hardened steel washers — circular, circular clipped, and beveled: ASTM F436/F436M
- (d) compressible washer-type direct tension indicators: ASTM F959/F959M
- (e) twist-off-type structural bolts — heavy hex and round: ASTM F3125/F3125M

**1.1.2** The inclusion of dimensional data in this Standard is not intended to imply that all products described herein are stock production sizes. Consumers should consult with suppliers concerning lists of available stock production sizes.

### 1.2 Dimensions

All dimensions in this Standard are in inches, unless stated otherwise, and apply to an unplated or uncoated product. When plating or coating is specified, the finished product dimensions shall be as agreed upon between supplier and purchaser. Symbols specifying geometric characteristics are in accord with ASME Y14.5.

### 1.3 Options

Options, where specified, shall be at the discretion of the supplier, unless otherwise agreed upon by the purchaser with the manufacturer or distributor.

### 1.4 Terminology

For definitions of terms relating to fastener dimensional or component features used in this Standard, refer to ASME B18.12.

### 1.5 Referenced Standards

Unless otherwise specified, the referenced Standard shall be the most recent issue at the time of order placement. The following is a list of publications referenced in this Standard:

- ASME B1.1, Unified Inch Screw Threads (UN and UNR Thread Form)
- ASME B1.2, Gages and Gaging for Unified Inch Screw Threads
- ASME B1.3, Screw Thread Gaging Systems for Dimensional Acceptability — Inch and Metric Screw Threads (UN, UNR, UNJ, M, and MJ)
- ASME B18.2.1, Square, Hex, Heavy Hex, and Askew Head Bolts and Hex, Heavy Hex, Hex Flange, Lobed Head, and Lag Screws (Inch Series)
- ASME B18.2.2, Nuts for General Applications: Machine Screw Nuts, Hex, Square, Hex Flange, and Coupling Nuts (Inch Series)
- ASME B18.2.9, Straightness Gage and Gaging for Bolts and Screws
- ASME B18.12, Glossary of Terms for Mechanical Fasteners
- ASME B18.18, Quality Assurance for Fasteners
- ASME B18.24, Part Identifying Number (PIN) Code System Standard for B18 Fastener Products
- ASME Y14.5, Dimensioning and Tolerancing
- Publisher: The American Society of Mechanical Engineers (ASME), Two Park Avenue, New York, NY 10016-5990 (www.asme.org)
- ASTM A194/A194M, Carbon Steel, Alloy Steel, and Stainless Steel Nuts for Bolts for High Pressure or High Temperature Service, or Both
- ASTM A563, Carbon and Alloy Steel Nuts

ASTM B695, Coatings of Zinc Mechanically Deposited on Iron and Steel  
ASTM F436/F436M, Hardened Steel Washers, Inch and Metric Dimensions  
ASTM F788, Surface Discontinuities of Bolts, Screws, and Studs, Inch and Metric Series  
ASTM F812, Surface Discontinuities of Nuts, Inch and Metric Series  
ASTM F959/F959M, Compressible-Washer-Type Direct Tension Indicators for Use With Structural Fasteners, Inch and Metric Series  
ASTM F2329/F2329M, Zinc Coating, Hot-Dip, Requirements for Application to Carbon and Alloy Steel Bolts, Screws, Washers, Nuts, and Special Threaded Fasteners  
ASTM F3125/F3125M, High Strength Structural Bolts, Steel and Alloy Steel, Heat Treated, 120 ksi (830 MPa) and 150 ksi (1040 MPa) Minimum Tensile Strength, Inch and Metric Dimensions  
Publisher: American Society for Testing and Materials (ASTM International), 100 Barr Harbor Drive, P.O. Box C700, West Conshohocken, PA 19428-2959 (www.astm.org)

## 2 HEAVY HEX STRUCTURAL BOLTS: ASTM F3125/F3125M

### 2.1 Heavy Hex Structural Bolt Dimensions

Bolts shall conform to the dimensions given in [Table 2.1-1](#). Formulas for heavy hex structural bolts are given in Nonmandatory Appendix A of ASME B18.2.1.

**2.1.1 Top of Head.** Top of head shall be full form and chamfered or rounded with the diameter of chamfer circle, or start of rounding being equal to the maximum width across flats within a tolerance of  $-15\%$  of the maximum across flats dimension. The shape of the top of the head may be flat, concave, or convex at the manufacturer's option. If the shape is concave or convex, head height as described in [para. 2.1.4](#) shall remain within specified limits at lowest or highest points, respectively.

**2.1.2 Width Across Flats.** The width across flats of heads shall be the distance measured perpendicular to the axis of the overall product between the two opposite sides of the head.

**2.1.3 Head Taper.** The maximum width across flats shall not be exceeded. No transverse section through the head between 25% and 75% of actual head height, as measured from the bearing surface, shall be less than the minimum width across flats.

**2.1.4 Head Height.** The head height shall be that overall distance measured parallel to the axis of the product from the top of the head to the bearing surface and shall include the thickness of the washer face. Raised grade and manufacturer's identification are excluded from head height.

**2.1.5 True Position of Head.** The head shall be located at true position with respect to the body within a tolerance zone having a diameter equivalent to 6% of the maximum width across flats at maximum material condition (MMC). For measurement purposes, hold the body a distance under the head equal to one diameter.

**2.1.6 Bearing Surface.** Bearing surface shall be flat and washer faced. However, a die seam across the bearing face shall be permissible. Diameter of washer face shall be equal to the maximum width across flats within a tolerance of  $-10\%$ .

Thickness of the washer face shall be not less than 0.015 in. nor greater than 0.025 in. for bolt sizes  $\frac{3}{4}$  in. and smaller, and not less than 0.015 in. nor greater than 0.035 in. for sizes larger than  $\frac{3}{4}$  in.

The plane of the bearing surface shall be perpendicular to the axis of the body within the full indicator movement (FIM) limits specified for total runout. Measurement of FIM shall extend as close to the periphery of the bearing surface as possible while the bolt is being held in a collet or other gripping device at a distance of one bolt diameter from the underside of the head. The angularity measurement shall be taken at a location to avoid interference from a die seam.

**2.1.7 Bolt Length.** The bolt length shall be the distance measured parallel to the axis of the product from the bearing surface of the head to the extreme end of the bolt including point. Bolts are normally furnished in  $\frac{1}{4}$ -in. length increments.

**Table 2.1-1 Dimensions of Heavy Hex Structural Bolts**

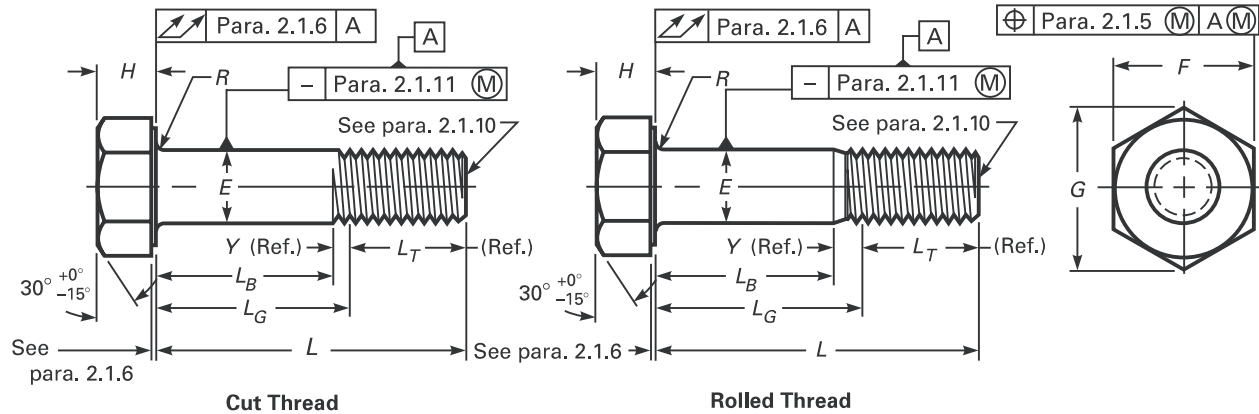

Nominal Size or Basic Product Diameter [Note (1)]	Body Diameter, E [Notes (2) and (3)]		Width Across Flats, F [Note (4)]			Width Across Corners, G		Head Height, H [Note (5)]			Radius of Fillet, R		Thread Length, L <sub>T</sub> [Note (6)]	Transition Thread Length, Y [Note (6)]	Maximum Total Runout of Bearing Surface FIM [Note (7)]	
	Max.	Min.	Nominal	Max.	Min.	Max.	Min.	Nominal	Max.	Min.	Max.	Min.	Ref.	Ref.		
1/2	0.500	0.515	0.482	7/8	0.875	0.850	1.010	0.969	5/16	0.323	0.302	0.031	0.009	1.00	0.19	0.016
5/8	0.625	0.642	0.605	1 1/16	1.062	1.031	1.227	1.175	25/64	0.403	0.378	0.062	0.021	1.25	0.22	0.019
3/4	0.750	0.768	0.729	1 1/4	1.250	1.212	1.443	1.383	15/32	0.483	0.455	0.062	0.021	1.38	0.25	0.022
7/8	0.875	0.895	0.852	1 7/16	1.438	1.394	1.660	1.589	35/64	0.563	0.531	0.062	0.031	1.50	0.28	0.025
1	1.000	1.022	0.976	1 5/8	1.625	1.575	1.876	1.796	39/64	0.627	0.591	0.093	0.062	1.75	0.31	0.028
1 1/8	1.125	1.149	1.098	1 13/16	1.812	1.756	2.093	2.002	11/16	0.718	0.658	0.093	0.062	2.00	0.34	0.032
1 1/4	1.250	1.277	1.223	2	2.000	1.938	2.309	2.209	25/32	0.813	0.749	0.093	0.062	2.00	0.38	0.035
1 3/8	1.375	1.404	1.345	2 3/16	2.188	2.119	2.526	2.416	27/32	0.878	0.810	0.093	0.062	2.25	0.44	0.038
1 1/2	1.500	1.531	1.470	2 3/8	2.375	2.300	2.742	2.622	15/16	0.974	0.902	0.093	0.062	2.25	0.44	0.041

GENERAL NOTE: See additional requirements in section 2.

NOTES:

- (1) See para. 2.4.1.
- (2) The body diameters are shown in this Table. Any swell or fin under the head or any die seam on the body shall not exceed the basic bolt diameter by more than the following:
  - (a) 0.030 in. for sizes 1/2 in.
  - (b) 0.050 in. for sizes 5/8 in. and 3/4 in.
  - (c) 0.060 in. for sizes over 3/4 in. through 1 1/4 in.
  - (d) 0.090 in. for sizes over 1 1/4 in.
- (3) See para. 2.1.9.4.
- (4) See paras. 2.1.2 and 2.1.3.
- (5) See paras. 2.1.1 and 2.1.4.
- (6) See para. 2.1.9.2.
- (7) See para. 2.1.6.

**2.1.8 Length Tolerance.** Bolt length tolerances shall be as tabulated below.

Nominal Bolt Size	Nominal Bolt Length Tolerance [Note (1)]	
	Through 6	Over 6
$\frac{1}{2}$	-0.12	-0.19
$\frac{5}{8}$	-0.12	-0.25
$\frac{3}{4}$ through 1	-0.19	-0.25
$1\frac{1}{8}$ through $1\frac{1}{2}$	-0.25	-0.25

NOTE: (1) There is no tolerance plus.

**2.1.9 Threads.** Threads shall be cut or rolled in accordance with ASME B1.1 Unified Coarse, Class 2A. Structural bolts shall not be undersized to accommodate heavy coatings. Threads that have been coated shall meet the requirements specified in ASTM F3125/F3125M.

**2.1.9.1 Thread Acceptability.** Unless otherwise specified by the purchaser, gaging for screw thread dimensional acceptability shall be in accordance with Gaging System 21, as specified in ASME B1.3.

**2.1.9.2 Thread Length.** The length of thread on bolts shall be controlled by the grip gaging length,  $L_G$  max., and the body length,  $L_B$  min.

Grip gaging length,  $L_G$ , is the distance measured parallel to the axis of bolt from the underhead bearing surface to the face of a noncounterbored or noncountersunk standard GO thread ring gage, assembled by hand as far as the thread will permit. It shall be used as the criterion for inspection. The maximum grip gaging length, as calculated and rounded to two decimal places for any bolt not threaded full length, shall be equal to the nominal bolt length minus the thread length ( $L_G$  max. =  $L$  nom. -  $L_T$ ). For bolts that are threaded full length,  $L_G$  max. defines the unthreaded length under the head and shall not exceed the length of 2.5 times the thread pitch for sizes up to and including 1 in. diameter, and 3.5 times the thread pitch for sizes larger than 1 in. diameter.  $L_G$  max. represents the minimum design grip length of the bolt and may be used for determining thread availability when selecting bolt lengths even though usable threads may extend beyond this point (see Table 2.1.9.2-1).

Thread length,  $L_T$ , is a reference dimension, intended for calculation purposes only, that represents the distance from the extreme end of the bolt to the last complete (full form) thread.

Body length,  $L_B$ , is the distance measured parallel to the axis of the bolt from the underhead bearing surface to the last scratch of thread, or to the top of the extrusion angle. It shall be used as a criterion for inspection. The minimum body length, as calculated and rounded to two decimal places, shall be equal to the maximum grip gaging length minus the transition thread length ( $L_B$  min. =  $L_G$  max. -  $Y$ ). Bolts of nominal lengths that have a calculated  $L_B$  min. length equal to or shorter than 2.5 times the thread pitch for sizes 1 in. diameter and smaller, and 3.5 times the thread pitch for sizes larger than 1 in. diameter, shall be threaded for full length (see Table 2.1.9.2-1).

Transition thread length,  $Y$ , is a reference dimension intended for calculation purposes only, that represents the length of incomplete threads and tolerance on grip gaging length.

**2.1.9.3 Incomplete Thread Diameter.** The major diameter of incomplete thread shall not exceed the actual major diameter of the full form thread.

**2.1.9.4 Fully Threaded Bolt Diameter.** The diameter of any unthreaded portion of a bolt considered fully threaded shall be between the minimum pitch diameter and maximum major diameter of the threads.

**2.1.10 Point.** Point shall be chamfered or rounded at the manufacturer's option from approximately 0.016 in. below the minor diameter of the thread. The first full formed thread at major diameter is located a distance no greater than 2 times the pitch measured from the end of the bolt. This distance is to be determined by measuring how far the point enters into a cylindrical NOT GO major diameter ring gage (reference gage, see ASME B1.2).

**2.1.11 Straightness.** Shanks of bolts shall be straight within the following limits at MMC:

(a) For bolts with nominal lengths to and including 12 in., the maximum camber shall be 0.006 in. per inch (0.006L) of bolt length.

(b) For bolts with nominal lengths over 12 in. to and including 24 in., the maximum camber shall be 0.008 in. per inch (0.008L) of length.

A suggested gage and gaging procedure for checking bolt straightness is given in ASME B18.2.9.

**Table 2.1.9.2-1 Maximum Grip Gaging Lengths and Minimum Body Lengths for Structural Bolts**

Nominal Length, <i>L</i>	Nominal Diameter and Thread Pitch																	
	1/2-13		5/8-11		3/4-10		7/8-9		1-8		1 1/8-7		1 1/4-7		1 3/8-6		1 1/2-6	
	<i>L<sub>G</sub></i> Max.	<i>L<sub>B</sub></i> Min.	<i>L<sub>G</sub></i> Max.	<i>L<sub>B</sub></i> Min.	<i>L<sub>G</sub></i> Max.	<i>L<sub>B</sub></i> Min.	<i>L<sub>G</sub></i> Max.	<i>L<sub>B</sub></i> Min.	<i>L<sub>G</sub></i> Max.	<i>L<sub>B</sub></i> Min.	<i>L<sub>G</sub></i> Max.	<i>L<sub>B</sub></i> Min.	<i>L<sub>G</sub></i> Max.	<i>L<sub>B</sub></i> Min.	<i>L<sub>G</sub></i> Max.	<i>L<sub>B</sub></i> Min.	<i>L<sub>G</sub></i> Max.	<i>L<sub>B</sub></i> Min.
1 1/4	...	...	...	...	...	...	...	...	...	...	...	...	...	...	...	...	...	...
1 1/2	0.50	0.31	...	...	...	...	...	...	...	...	...	...	...	...	...	...	...	...
1 3/4	0.75	0.56	0.50	0.28	...	...	...	...	...	...	...	...	...	...	...	...	...	...
2	1.00	0.81	0.75	0.53	0.62	0.37	...	...	...	...	...	...	...	...	...	...	...	...
2 1/4	1.25	1.06	1.00	0.78	0.87	0.62	0.75	0.47	...	...	...	...	...	...	...	...	...	...
2 1/2	1.50	1.31	1.25	1.03	1.12	0.87	1.00	0.72	0.75	0.44	...	...	...	...	...	...	...	...
2 3/4	1.75	1.56	1.50	1.28	1.37	1.12	1.25	0.97	1.00	0.69	...	...	...	...	...	...	...	...
3	2.00	1.81	1.75	1.53	1.62	1.37	1.50	1.22	1.25	0.94	1.00	0.66	1.00	0.62	...	...	...	...
3 1/4	2.25	2.06	2.00	1.78	1.87	1.62	1.75	1.47	1.50	1.19	1.25	0.91	1.25	0.87	...	...	...	...
3 1/2	2.50	2.31	2.25	2.03	2.12	1.87	2.00	1.72	1.75	1.44	1.50	1.16	1.50	1.12	1.25	0.81	1.25	0.81
3 3/4	2.75	2.56	2.50	2.28	2.37	2.12	2.25	1.97	2.00	1.69	1.75	1.41	1.75	1.37	1.50	1.06	1.50	1.06
4	3.00	2.81	2.75	2.53	2.62	2.37	2.50	2.22	2.25	1.94	2.00	1.66	2.00	1.62	1.75	1.31	1.75	1.31
4 1/4	3.25	3.06	3.00	2.78	2.87	2.62	2.75	2.47	2.50	2.19	2.25	1.91	2.25	1.87	2.00	1.56	2.00	1.56
4 1/2	3.50	3.31	3.25	3.03	3.12	2.87	3.00	2.72	2.75	2.44	2.50	2.16	2.50	2.12	2.25	1.81	2.25	1.81
4 3/4	3.75	3.56	3.50	3.28	3.37	3.12	3.25	2.97	3.00	2.69	2.75	2.41	2.75	2.37	2.50	2.06	2.50	2.06
5	4.00	3.81	3.75	3.53	3.62	3.37	3.50	3.22	3.25	2.94	3.00	2.66	3.00	2.62	2.75	2.31	2.75	2.31
5 1/4	4.25	4.06	4.00	3.78	3.87	3.62	3.75	3.47	3.50	3.19	3.25	2.91	3.25	2.87	3.00	2.56	3.00	2.56
5 1/2	4.50	4.31	4.25	4.03	4.12	3.87	4.00	3.72	3.75	3.44	3.50	3.16	3.50	3.12	3.25	2.81	3.25	2.81
5 3/4	4.75	4.56	4.50	4.28	4.37	4.12	4.25	3.97	4.00	3.69	3.75	3.41	3.75	3.37	3.50	3.06	3.50	3.06
6	5.00	4.81	4.75	4.53	4.62	4.37	4.50	4.22	4.25	3.94	4.00	3.66	4.00	3.62	3.75	3.31	3.75	3.31
6 1/4	5.25	5.06	5.00	4.78	4.87	4.62	4.75	4.47	4.50	4.19	4.25	3.91	4.25	3.87	4.00	3.56	4.00	3.56
6 1/2	5.50	5.31	5.25	5.03	5.12	4.87	5.00	4.72	4.75	4.44	4.50	4.16	4.50	4.12	4.25	3.81	4.25	3.81
6 3/4	5.75	5.56	5.50	5.28	5.37	5.12	5.25	4.97	5.00	4.69	4.75	4.41	4.75	4.37	4.50	4.06	4.50	4.06
7	6.00	5.81	5.75	5.53	5.62	5.37	5.50	5.22	5.25	4.94	5.00	4.66	5.00	4.62	4.75	4.31	4.75	4.31
7 1/4	6.25	6.06	6.00	5.78	5.87	5.62	5.75	5.47	5.50	5.19	5.25	4.91	5.25	4.87	5.00	4.56	5.00	4.56
7 1/2	6.50	6.31	6.25	6.03	6.12	5.87	6.00	5.72	5.75	5.44	5.50	5.16	5.50	5.12	5.25	4.81	5.25	4.81
7 3/4	6.75	6.56	6.50	6.28	6.37	6.12	6.25	5.97	6.00	5.69	5.75	5.41	5.75	5.37	5.50	5.06	5.50	5.06
8	7.00	6.81	6.75	6.53	6.62	6.37	6.50	6.22	6.25	5.94	6.00	5.66	6.00	5.62	5.75	5.31	5.75	5.31
8 1/4	7.25	7.06	7.00	6.78	6.87	6.62	6.75	6.47	6.50	6.19	6.25	5.91	6.25	5.87	6.00	5.56	6.00	5.56
8 1/2	7.50	7.31	7.25	7.03	7.12	6.87	7.00	6.72	6.75	6.44	6.50	6.16	6.50	6.12	6.25	5.81	6.25	5.81
8 3/4	7.75	7.56	7.50	7.28	7.37	7.12	7.25	6.97	7.00	6.69	6.75	6.41	6.75	6.37	6.50	6.06	6.50	6.06
9	8.00	7.81	7.75	7.53	7.62	7.37	7.50	7.22	7.25	6.94	7.00	6.66	7.00	6.62	6.75	6.31	6.75	6.31
9 1/4	8.25	8.06	8.00	7.78	7.87	7.62	7.75	7.47	7.50	7.19	7.25	6.91	7.25	6.87	7.00	6.56	7.00	6.56
9 1/2	8.50	8.31	8.25	8.03	8.12	7.87	8.00	7.72	7.75	7.44	7.50	7.16	7.50	7.12	7.25	6.81	7.25	6.81
9 3/4	8.75	8.56	8.50	8.28	8.37	8.12	8.25	7.97	8.00	7.69	7.75	7.41	7.75	7.37	7.50	7.06	7.50	7.06
10	9.00	8.81	8.75	8.53	8.62	8.37	8.50	8.22	8.25	7.94	8.00	7.66	8.00	7.62	7.75	7.31	7.75	7.31



## 2.2 Material and Mechanical Properties

Chemical and mechanical properties of steel bolts shall conform to ASTM F3125/F3125M.

## 2.3 Finish

Unless otherwise specified, bolts shall be supplied with a plain (as-processed) finish, unplated or uncoated. If a finish is required, it shall conform to the requirements of ASTM F3125/F3125M.

## 2.4 Designation

(a) Heavy hex structural bolts shall be designated by the following data in the sequence shown: product name, specification, nominal size (fractional or decimal equivalent), threads per inch, product length (fractional or two-decimal place equivalent), material (including specification, grade, and type), and protective finish (if required).

EXAMPLES:

- (1) Heavy Hex Structural Bolt, ASME B18.2.6,  $\frac{3}{4}$  – 10 × 2 $\frac{1}{4}$ , ASTM F3125/F3125M Grade A325 Type 1, Hot-Dip Galvanized per ASTM F2329/F2329M
  - (2) Heavy Hex Structural Bolt, ASTM F3125/F3125M Grade A325 Type 1,  $\frac{3}{4}$  – 10 × 2 $\frac{1}{4}$ , Hot-Dip Galvanized per ASTM F2329/F2329M
- (b) For a part identifying number (PIN), refer to ASME B18.24.

**2.4.1 Nominal Size.** When specifying nominal size in decimals, zeros preceding the decimal shall be used and the fourth decimal place shall be omitted.

EXAMPLES:

- (1) Heavy Hex Structural Bolt, ASME B18.2.6, 0.750 – 10 × 2.25, ASTM F3125/F3125M Grade A325 Type 1, Hot-Dip Galvanized per ASTM F2329/F2329M
- (2) Heavy Hex Structural Bolt, ASTM F3125/F3125M Grade A325 Type 1, 0.750 – 10 × 2.25, Hot-Dip Galvanized per ASTM F2329/F2329M

## 2.5 Identification Symbols

When raised, identification marking symbols on the tops of heads for bolt sizes  $\frac{5}{8}$  in. and smaller shall project not less than 0.005 in. above the surface nor more than 0.015 in. over the specified maximum head height. Bolt sizes larger than  $\frac{5}{8}$  in. shall project not less than the equivalent in inches of 0.0075 times the basic bolt diameter above the surface nor more than 0.030 in. over the specified maximum head height.

**2.5.1 Grade Symbols.** Each bolt shall be marked in accordance with the requirements of ASTM F3125/F3125M.

**2.5.2 Source Symbols.** Each bolt shall be marked to identify the source (manufacturer or private label distributor) accepting the responsibility for conformance to this and other applicable specifications.

## 2.6 Workmanship

The allowable limits, inspection, and evaluation of surface discontinuities, quench cracks, forging cracks, head bursts, shear bursts, seams, folds, thread laps, voids, tool marks, nicks, and gouges shall be in accordance with ASTM F788.

## 2.7 Quality Assurance

Unless otherwise specified, products shall be furnished in accordance with ASME B18.18.

# 3 HEAVY HEX NUTS: ASTM A563 AND ASTM A194/A194M

## 3.1 Nut Dimensions

Nuts shall conform to the dimensions given in [Table 3.1-1](#). Heavy hex nut formulas for thickness, width across flats, and width across corners are given in ASME B18.2.2, Nonmandatory Appendix A.

**3.1.1 Width Across Flats.** The width across flats of heavy hex nuts shall be the overall distance measured, perpendicular to the axis of the nut, between two opposite sides of the nut in accordance with [Table 3.1-1](#). For milled-from-bar hex nuts, the nominal bar size used shall be the closest commercially available size to the specified basic width across flats of the nut. If the bar dimensions will not conform to the dimensions in [Table 3.1-1](#), the manufacturers must obtain approval from the purchaser prior to manufacturing.

**Table 3.1-1 Dimensions of Heavy Hex Nuts for Use With Structural Bolts**

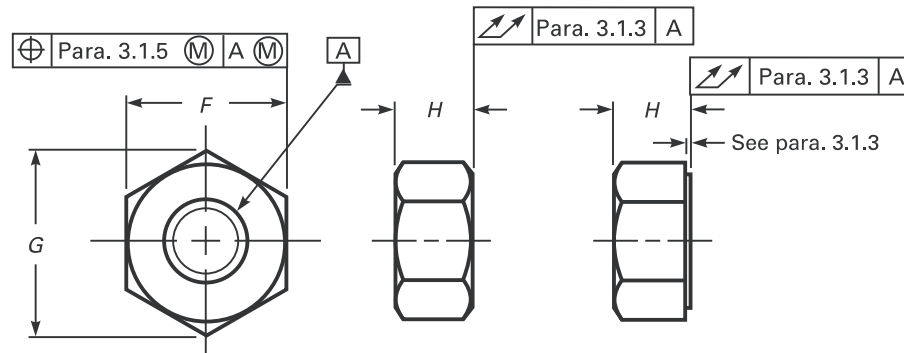

Nominal Size or Basic Major Diameter of Thread [Note (1)]	Width Across Flats, F [Note (2)]			Width Across Corners, G [Note (3)]		Thickness, H [Note (4)]			Total Runout of Bearing Face FIM, Heavy Hex Nuts, Specified Proof Load [Note (5)]		
	Nominal	Max.	Min.	Max.	Min.	Nominal	Max.	Min.	<150,000 psi	≥150,000 psi	
1/2	0.500	7/8	0.875	0.850	1.010	0.969	31/64	0.504	0.464	0.023	0.016
5/8	0.625	1 1/16	1.062	1.031	1.227	1.175	39/64	0.631	0.587	0.025	0.018
3/4	0.750	1 1/4	1.250	1.212	1.443	1.382	47/64	0.758	0.710	0.027	0.020
7/8	0.875	1 7/16	1.438	1.394	1.660	1.589	55/64	0.885	0.833	0.029	0.022
1	1.000	1 5/8	1.625	1.575	1.876	1.796	63/64	1.012	0.956	0.031	0.024
1 1/8	1.125	1 13/16	1.812	1.756	2.093	2.002	1 7/64	1.139	1.079	0.033	0.027
1 1/4	1.250	2	2.000	1.938	2.309	2.209	1 7/32	1.251	1.187	0.035	0.030
1 3/8	1.375	2 3/16	2.188	2.119	2.526	2.416	1 11/32	1.378	1.310	0.038	0.033
1 1/2	1.500	2 3/8	2.375	2.300	2.742	2.622	1 15/32	1.505	1.433	0.041	0.036

GENERAL NOTE: See additional requirements in section 3. Complete table included in ASME B18.2.2.

NOTES:

- (1) See para. 2.4.1.
- (2) See para. 3.1.1.
- (3) See para. 3.1.4.
- (4) See para. 3.1.2.
- (5) See para. 3.1.3.

Maximum width across flats shall not be exceeded (except as stated in the previous paragraph). No transverse section through the nut between 25% and 75% of the actual nut thickness, as measured from the bearing surface, shall be less than the minimum width across flats.

**3.1.2 Nut Thickness.** The nut thickness shall be the overall distance measured parallel to the axis of the nut, from the top of the nut to the bearing surface, and shall include the thickness of the washer face where provided.

**3.1.3 Tops and Bearing Surfaces.** Nuts may be double chamfered or have a washer faced bearing surface and chamfered top.

The diameter of chamfer circle on double-chamfered nuts and diameter of washer face shall be within the limits of the maximum width across flats and 95% of the minimum width across flats.

The tops of washer faced nuts shall be flat and the diameter of chamfer circle shall be equal to the maximum width across flats within a tolerance of -15%. The length of chamfer at hex corners shall be 5% to 15% of the basic thread diameter. The surface of chamfer may be slightly convex or rounded.

Bearing surfaces shall be flat and, unless otherwise specified, shall be perpendicular to the axis of the threaded hole within the total runout (FIM) tabulated for the respective nut size, type, and strength level.

**3.1.4 Corner Fill.** A rounding or lack of fill at junction of hex corners with chamfer shall be permissible, provided the width across corners is within specified limits at and beyond a distance equal to 17.5% of the basic thread diameter from the chamfered faces.

**3.1.5 Position of Hexagon to Tapped Hole.** At maximum material condition, the nut body shall be located at true position with respect to the thread pitch diameter within a tolerance zone having a diameter equivalent to 4% of the maximum width across flats for 1½ in. nominal size nuts or smaller.

**3.1.6 Countersink.** Tapped hole shall be countersunk on the bearing face or faces. The maximum countersink diameter shall be 1.08 times the thread basic (nominal) major diameter. No part of the threaded portion shall project beyond the bearing surface.

**3.1.7 Threads.** Threads shall be Class 2B in accordance with ASME B1.1.

**3.1.7.1 Thread Gaging.** Unless otherwise specified by the purchaser, gaging for screw thread dimensional acceptability shall be in accordance with Gaging System 21 as specified in ASME B1.3.

**3.1.7.2 Overtapping.** When nuts are hot-dip or mechanically deposited zinc-coated, they shall be overtapped or tapped after coating in accordance with the provisions of ASTM A563.

## 3.2 Materials

Chemical and mechanical properties of heavy hex nuts shall conform to ASTM A563 grades or ASTM A194/A194M, Grade 2H. The nut's grade shall have a proof load capacity equal to or greater than the ultimate tensile strength of the bolt it will be used with.

## 3.3 Finish

Unless otherwise specified, nuts shall be supplied with a plain (as-processed) finish, unplated or uncoated. If a finish is required, it shall conform to those approved in the applicable material standard.

## 3.4 Designation

(a) Nuts shall be designated by the following data in the sequence shown: product name, specification, nominal size (fraction or decimal), threads per inch, material (including specification where necessary), and protective finish (if required).

EXAMPLE: Heavy Hex Nut, ASME B18.2.6, ½ – 13, ASTM A563, Grade C, Plain Finish

(b) For a part identifying number (PIN), refer to ASME B18.24.

## 3.5 Identification Symbols

**3.5.1 Grade Symbols.** Each nut shall be marked in accordance with the requirements of ASTM A563 or ASTM A194/A194M, Grade 2H, as applicable.

**3.5.2 Source Symbols.** Each nut shall be marked to identify the source (manufacturer or private label distributor) accepting the responsibility for conformance to this and other applicable specifications.

## 3.6 Workmanship

Surface discontinuity limits shall be in accordance with ASTM F812.

## 3.7 Quality Assurance

Unless otherwise specified, products shall be furnished in accordance with ASME B18.18.

## 4 HARDENED STEEL WASHERS: ASTM F436/F436M

### 4.1 Circular and Circular Clipped Washers

**4.1.1 Circular and Circular Clipped Washer Dimensions.** All circular and circular clipped washers shall conform to the dimensions given in [Table 4.1.1-1](#).

**Table 4.1.1-1 Dimensions for Hardened Steel Circular and Circular Clipped Washers**

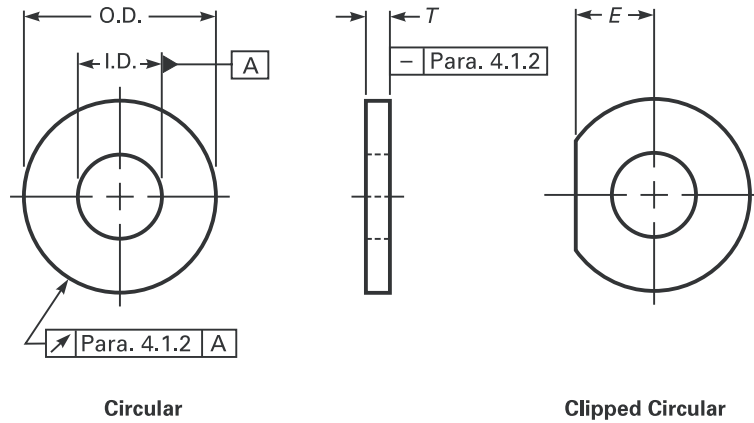

Basic Size or Nominal Washer Size [Note (1)]	Inside Diameter, I.D.			Outside Diameter, O.D.			Thickness, <i>T</i>		Minimum Edge Distance, <i>E</i> [Note (2)]
	Nominal	Min.	Max.	Nominal	Min.	Max.	Min.	Max.	
1/2	0.531	0.531	0.563	1.063	1.031	1.095	0.097	0.177	0.438
5/8	0.688	0.688	0.720	1.313	1.281	1.345	0.122	0.177	0.547
3/4	0.813	0.813	0.845	1.469	1.437	1.501	0.122	0.177	0.656
7/8	0.938	0.938	0.970	1.750	1.718	1.782	0.136	0.177	0.766
1	1.063	1.063	1.085	2.000	1.937	2.063	0.136	0.177	0.875
1 1/8	1.188	1.188	1.251	2.250	2.187	2.313	0.136	0.177	0.984
1 1/4	1.375	1.375	1.438	2.500	2.437	2.563	0.136	0.177	1.094
1 3/8	1.500	1.500	1.563	2.750	2.687	2.813	0.136	0.177	1.203
1 1/2	1.625	1.625	1.688	3.000	2.937	3.063	0.136	0.177	1.313

NOTES:

- (1) Nominal washer sizes are intended for use with comparable nominal bolt diameters.
- (2) Clipped edge, *E*, shall not be closer than 0.875 times the nominal bolt diameter from the center of the washer.

**4.1.2 Tolerances.** Washer inside diameter, outside diameter, thickness, and edge distance shall be in accordance with Table 4.1.1-1. The deviation from flatness shall not exceed 0.010 in. per inch as the maximum deviation from a straight edge placed on the cut side. Circular runout of the outside diameter with respect to the hole shall not exceed 0.030 FIM. Burrs shall not project above immediately adjacent washer surface by more than 0.010 in.

**4.1.3 Finish.** Unless otherwise specified, washers shall be supplied with a plain (as-processed) finish. If a finish is required, it shall conform to those approved in the applicable material standard.

**4.1.4 Materials and Mechanical Properties.** Materials and properties shall conform to the requirements specified in ASTM F436/F436M.

**4.1.5 Workmanship.** Washers shall be free of excess mill scale, excess coatings, and foreign material on bearing surfaces. Arc and gas cut washers shall be free of metal splatter.

**4.1.6 Designation**

(a) Washers shall be designated by the following data in the sequence shown: product name, specification, nominal size (fraction or decimal), material specification, and protective finish (if required).

EXAMPLES:

- (1) Hardened Steel Circular Washer, ASME B18.2.6, 1 1/8, ASTM F436/F436M, Mechanical Zinc, ASTM B695 Class 55, Type 1
- (2) Hardened Steel Circular Washer, ASME B18.2.6, ASTM F436/F436M, Type 1, 1 1/8, Mechanical Zinc per ASTM B695 Class 55

(b) For a part identifying number (PIN), refer to ASME B18.24.

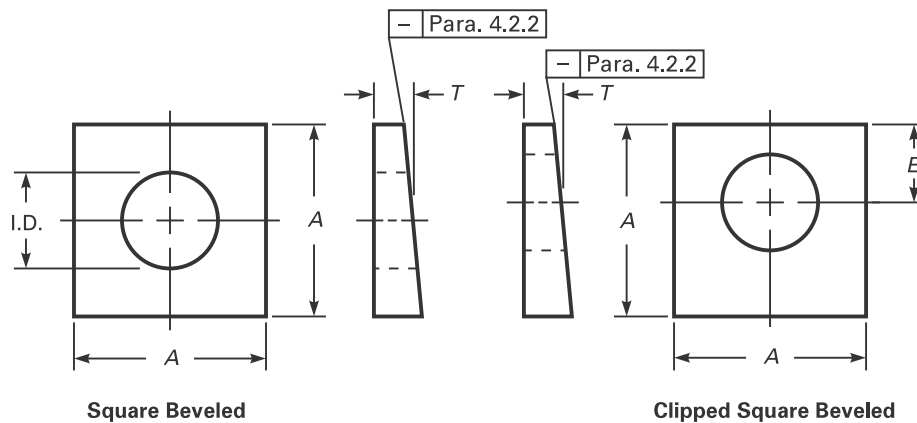
**Table 4.2.1-1 Dimensions of Hardened Beveled Washers With Slope or Taper in Thickness 1:6**

Nominal Washer Size [Note (1)]	Inside Diameter, I.D.			Minimum Side Length, A [Note (2)]	Thickness, T (Ref.) [Note (3)]	Minimum Edge Distance, E [Note (4)]
	Nominal	Min.	Max.			
$\frac{1}{2}$	0.500	0.531	0.563	1.750	0.313	0.438
$\frac{5}{8}$	0.625	0.688	0.720	1.750	0.313	0.547
$\frac{3}{4}$	0.750	0.813	0.845	1.750	0.313	0.656
$\frac{7}{8}$	0.875	0.938	0.970	1.750	0.313	0.766
1	1.000	1.125	1.188	1.750	0.313	0.875
$1\frac{1}{8}$	1.125	1.250	1.313	2.250	0.313	0.984
$1\frac{1}{4}$	1.250	1.375	1.438	2.250	0.313	1.094
$1\frac{3}{8}$	1.375	1.500	1.563	2.250	0.313	1.203
$1\frac{1}{2}$	1.500	1.625	1.688	2.250	0.313	1.313

## NOTES:

- (1) Nominal washer sizes are intended for use with comparable nominal bolt diameters.
- (2) Nonclipped washers may be rectangular providing neither side dimension is less than A.
- (3) The thickness is measured on the centerline of the hole from the sloped to the flat surface.
- (4) Clipped edge, E, shall not be closer than 0.875 times the nominal bolt diameter from the center of the washer.

**4.1.7 Identification Symbols.** Grade and source marking and symbols shall conform to the requirements of ASTM F436/F436M. The source marking is intended to identify the source accepting the responsibility for the conformance to this and other applicable specifications.

**4.1.8 Quality Assurance.** Unless otherwise specified, products shall be furnished in accordance with ASME B18.18.

## 4.2 Square and Clipped Square Beveled Washers

**4.2.1 Square Beveled Washer Dimensions.** All square beveled and clipped square beveled washers shall conform to the dimensions given in Table 4.2.1-1.

**4.2.2 Tolerances.** Tolerances for inside diameter for beveled washers shall be in accordance with Table 4.2.1-1. The flatness shall not exceed 0.010 in. as the maximum deviation from a straight edge placed on the cut side. Burrs shall not project above immediately adjacent washer surface by more than 0.010 in. for smaller than 1 in. and 0.015 in. for 1 in to  $1\frac{1}{2}$  in. The slope or taper in thickness shall be 0.98:6 to 1.02:6.

**4.2.3 Finish.** Unless otherwise specified, washers shall be supplied with a plain (as-processed) finish. If a finish is required, it shall conform to those approved in the material standard.

**4.2.4 Materials and Mechanical Properties.** Materials and properties shall conform to the requirements established by ASTM F436/F436M.

**4.2.5 Workmanship.** Washers shall be free of seams, laps, loose scale, irregular surfaces, and any defects affecting serviceability.

#### 4.2.6 Designation

(a) Washers shall be designated by the following data in the sequence shown: product name, specification, nominal washer size (fraction or decimal), material specification, and protective finish (if required).

EXAMPLES:

- (1) Hardened Steel Square Washer, ASME B18.2.6,  $1\frac{1}{8}$ , ASTM F436/F436M Type 1, Mechanical Zinc, ASTM B695 Class 55
- (2) Hardened Steel Square Washer, ASME B18.2.6, ASTM F436/F436M Type 1,  $1\frac{1}{8}$ , Mechanical Zinc, ASTM B695 Class 55

(b) For a part identifying number (PIN), refer to ASME B18.24.

**4.2.7 Identification Symbols.** Grade and source marking and symbols shall conform to the requirements of ASTM F436/F436M. The source marking is intended to identify the source accepting the responsibility for conformance to this and other applicable specifications.

**4.2.8 Quality Assurance.** Unless otherwise specified, products shall be furnished in accordance with ASME B18.18.

## 5 COMPRESSIBLE WASHER-TYPE DIRECT TENSION INDICATORS: ASTM F959/F959M

### 5.1 Direct Tension Indicator Dimensions

All washer-type direct tension indicators, Types 325 and 490, shall conform to the dimensions given in [Table 5.1-1](#). Additional characteristics to accommodate the necessary features for self-indicating type indicator washers are permissible.

### 5.2 Finish

Unless otherwise specified, direct tension indicators shall be supplied with a plain (as-processed) finish, unplated or uncoated. If a finish is required, it shall conform to those approved in the material standard.

### 5.3 Materials and Properties

Direct tension indicators shall conform to the requirements of ASTM F959/F959M. Self-indicating type indicator washers shall meet all of the performance requirements of ASTM F959/F959M and the dimensional requirements in this Standard.

### 5.4 Workmanship

The workmanship shall be smooth and free of burrs, laps, seams, excess mill scale, and foreign material on bearing surfaces or on protrusions, or other defects that would make them unsuitable for intended application.

### 5.5 Designation

(a) Compressible washer-type direct tension indicators shall be designated by the following data in the sequence shown: product name, specification, nominal size (fractional or decimal equivalent), Type (325-1, 325-3, 490-1, or 490-3), and finish (plain, zinc, etc.).

EXAMPLES:

- (1) DTI, ASME B18.2.6,  $\frac{1}{2}$ , per ASTM F959/F959M, Type 325-1, Plain Finish
- (2) DTI, ASME B18.2.6, ASTM F959/F959M,  $\frac{1}{2}$ , Type 325-1, Plain Finish

(b) For a part identifying number (PIN), refer to ASME B18.24.

### 5.6 Identification Symbols or Markings

Type, lot number, and source marking symbols shall conform to the requirements of ASTM F959/F959M.

### 5.7 Quality Assurance

Unless otherwise specified, products shall be furnished in accordance with ASME B18.18.

**Table 5.1-1 Dimensions for Compressible Washer-Type Direct Tension Indicators**

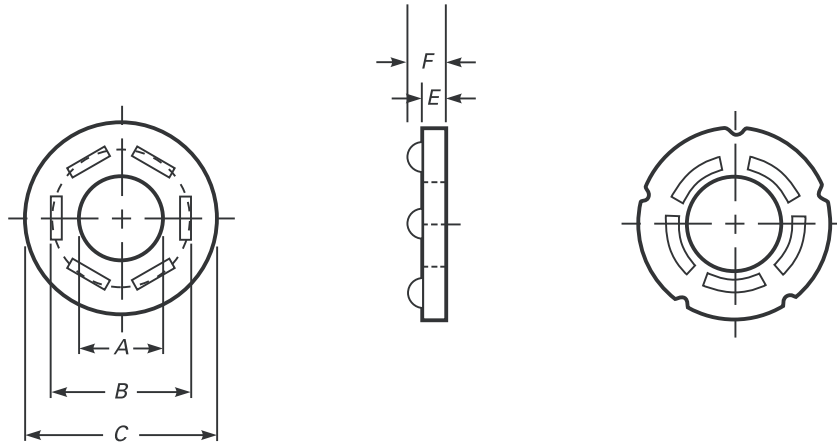

**Straight-Side Protrusion Type**

**Curved Protrusion Type With Optional Outside Notches**

Direct Tension Indicator Size [Note (1)]	All Types					Types 325-1, 325-3		Types 490-1, 490-3	
	Inside Diameter, A		Protrusion Tangential Diameter, B	Thickness		Outside Diameter, C		Outside Diameter, C	
				Without Protrusion, E	With Protrusion, F				
	Min.	Max.	Max.	Min.	Max.	Min.	Max.	Min.	Max.
1/2	0.520	0.527	0.788	0.104	0.180	1.031	1.187	1.031	1.375
5/8	0.651	0.658	0.956	0.126	0.220	1.281	1.375	1.281	1.625
3/4	0.783	0.790	1.125	0.126	0.240	1.437	1.625	1.437	1.750
7/8	0.914	0.921	1.294	0.142	0.260	1.718	1.875	1.718	2.000
1	1.043	1.052	1.463	0.158	0.270	1.937	2.000	1.937	2.250
1 1/8	1.174	1.183	1.631	0.158	0.280	2.187	2.250	2.187	2.500
1 1/4	1.306	1.315	1.800	0.158	0.280	2.437	2.500	2.437	2.750
1 3/8	1.437	1.446	1.969	0.158	0.280	2.687	2.750	2.687	3.000
1 1/2	1.568	1.577	2.138	0.158	0.280	2.937	3.000	2.937	3.250

GENERAL NOTES:

- (a) Additional requirements are in [section 5](#).
- (b) Protrusions are to be equally spaced. The number of protrusions may vary provided there are no fewer than four and performance requirements are met.
- (c) All dimensions are as-formed, prior to application of coating and/or plating.

NOTE: (1) Nominal direct tension indicator sizes are intended for use with fasteners of the same nominal diameter.

## 6 TWIST-OFF-TYPE STRUCTURAL BOLTS, HEAVY HEX AND ROUND: ASTM F3125/F3125M

### 6.1 Twist-Off-Type Structural Bolt Dimensions

**6.1.1 Heavy Hex Heads.** Heavy hex head bolts shall conform to the dimensions included in [Table 6.1.1-1](#).

**6.1.1.1 Top of Head.** The top of head shall be full formed and chamfered or rounded with the diameter of the chamfer circle or start of rounding being equal to the maximum width across flats within a tolerance of  $-15\%$ .

**6.1.1.2 Width Across Flats.** The width across flats of heads shall be the distance measured perpendicular to the axis of the product, overall between two opposite sides of the head.

**6.1.1.3 Head Taper.** Maximum width across flats shall not be exceeded. No transverse section through the head between 25% and 75% of actual head height, as measured from the bearing surface, shall be less than the minimum width across flats.

**6.1.1.4 Head Height.** The head height shall be that overall distance measured parallel to the axis of the product from the top of the head to the bearing surface and shall include the thickness of the washer face. Raised grade and manufacturer's identification are excluded from head height.

**6.1.2 Round Heads.** Round head dimensions shall be in accordance with [Table 6.1.1-1](#).

**6.1.2.1 Top of Head.** The top of the round head shall be spherical and may be underfilled within a circle approximating the nominal bolt diameter.

**6.1.2.2 Head Diameter.** The round head configuration shall have a head diameter in accordance with [Table 6.1.1-1](#). The heads are not normally machined or trimmed, thus the circumference may be irregular with a rounded or flat edge.

### 6.2 True Position of Head

The head shall be located at true position with respect to the body within a tolerance zone having a diameter equivalent to 6% of the maximum width across flats at maximum material condition. For measurement purposes, hold the body a distance under the head equal to one diameter.

### 6.3 Bearing Surface

The hex head washer face diameter shall be equal to the maximum width across flats within a tolerance of  $-10\%$  and have a thickness not less than 0.015 in. nor greater than 0.025 in. for bolt sizes  $\frac{3}{4}$  in. and smaller, and not less than 0.015 in. nor greater than 0.035 in. for sizes larger than  $\frac{3}{4}$  in.

The plane of the bearing surface shall be flat and perpendicular to the axis of the body within the FIM limits specified for total runout. Measurement of FIM shall extend as close to the periphery of the bearing surface as possible while the bolt is being held in a collet or other gripping device at a distance of one bolt diameter from the underside of the head.

A die seam across the bearing surface is not permissible.

### 6.4 Bolt Length

The bolt length shall be the distance measured parallel to the axis of the bolt from the bearing surface of the head to the center point of the groove through which shear will occur. Bolts are normally supplied in  $\frac{1}{4}$ -in. length increments.

### 6.5 Length Tolerance

Bolt length tolerances shall be as tabulated below.

Nominal Bolt Size	Nominal Bolt Length Tolerance <a href="#">[Note (1)]</a>	
	Through 6	Over 6
$\frac{1}{2}$	-0.12	-0.19
$\frac{5}{8}$	-0.12	-0.25
$\frac{3}{4}$ through 1	-0.19	-0.25
$1\frac{1}{8}$ through $1\frac{1}{2}$	-0.25	-0.25

NOTE: (1) There is no tolerance plus.



**Table 6.1.1-1 Dimensions of Twist-Off-Type Structural Bolts: Heavy Hex Head and Round Head Configurations**

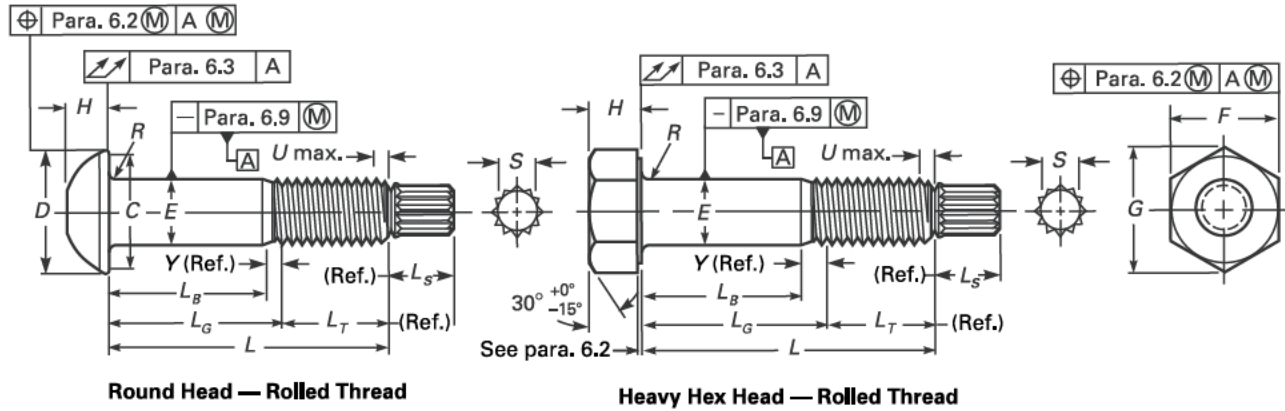

**Round Head — Rolled Thread**

**Heavy Hex Head — Rolled Thread**

Nominal Size or Basic Major Diameter of Thread and Threads per Inch	Heavy Hex Head		Heavy Hex and Round Head				Round Head		Thread Length, $L_T$ [Note (5)]	Spline Length, $L_S$ [Note (6)]	Spline Width Across Flats, $S$ [Note (6)]	Maximum Center of Groove to First Fully Formed Thread, $U$ [Note (7)]	Maximum Transition Thread Length, $Y$ [Note (5)]	Maximum Total Runout of Bearing Surface FIM, [Note (4)]					
	Width Across Flats, $F$ [Note (1)]		Width Across Corners, $G$		Head Height, $H$ [Note (2)]		Full-Size Body Dia., $E$								Head Dia., $D$ [Note (3)]	Bearing Dia., $C$ [Note (4)]	Radius of Fillet, $R$		
	Max.	Min.	Max.	Min.	Max.	Min.	Max.	Min.							Max.	Min.	Max.	Min.	Ref.
$\frac{1}{2}$ -13	0.500	0.875	0.850	1.010	0.969	0.323	0.302	0.515	0.482	1.126	0.890	0.031	0.009	1.00	0.50	0.32	0.192	0.19	0.016
$\frac{5}{8}$ -11	0.625	1.062	1.031	1.227	1.175	0.403	0.378	0.642	0.605	1.313	1.102	0.062	0.021	1.25	0.60	0.43	0.227	0.22	0.019
$\frac{3}{4}$ -10	0.750	1.250	1.212	1.443	1.383	0.483	0.455	0.768	0.729	1.580	1.338	0.062	0.021	1.38	0.65	0.53	0.250	0.25	0.022
$\frac{7}{8}$ -9	0.875	1.438	1.394	1.660	1.589	0.563	0.531	0.895	0.852	1.880	1.535	0.062	0.031	1.50	0.72	0.61	0.278	0.28	0.025
1-8	1.000	1.625	1.575	1.876	1.796	0.627	0.591	1.022	0.976	2.158	1.771	0.093	0.062	1.75	0.80	0.70	0.313	0.31	0.028
$1\frac{1}{8}$ -7	1.125	1.812	1.756	2.093	2.002	0.718	0.658	1.149	1.098	2.375	1.991	0.093	0.062	2.00	0.90	0.80	0.367	0.34	0.032
$1\frac{1}{4}$ -7	1.250	2.000	1.938	2.309	2.209	0.813	0.749	1.277	1.223	2.760	2.213	0.093	0.062	2.00	1.00	0.90	0.367	0.38	0.035

NOTES:

- (1) See para. 6.1.1.2.
- (2) See para. 6.1.1.4.
- (3) See para. 6.1.2.2.
- (4) See para. 6.3.
- (5) See para. 6.6.2.
- (6) See para. 6.7.
- (7) See para. 6.8.

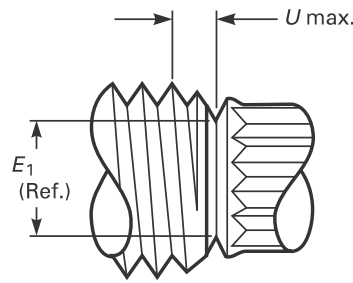
**Figure 6.8.1-1 Groove Diameter**

## 6.6 Threads

Threads shall be in the Unified Inch coarse series (UNRC Series), Class 2A. Unless otherwise specified, zinc-coated bolts to be used with nuts that have been tapped oversize in accordance with ASTM A563 shall have Class 2A threads before mechanically deposited zinc coating.

**6.6.1 Thread Acceptability.** Acceptability of screw threads shall be in accordance with Gaging System 21, as specified in ASME B1.3.

**6.6.2 Thread Length.** The length of thread on bolts shall be controlled by the grip gaging length,  $L_G$  max., and the body length,  $L_B$  min.

(a)  $L_G$  max. is the distance measured parallel to the axis of bolt from the underhead bearing surface to the face of a noncountersunk standard GO thread ring gage, assembled by hand as far as the thread will permit. It shall be used as the criterion for inspection. The maximum grip gaging length, as calculated and rounded to two decimal places for any bolt not threaded full length, shall be equal to the nominal bolt length minus the thread length ( $L_G$  max. =  $L$  nom. -  $L_T$ ).

For bolts that are threaded full length,  $L_G$  max. defines the unthreaded length under the head and shall not exceed the length of 2.5 times the thread pitch for sizes up to and including 1 in. diameter, and 3.5 times the thread pitch for sizes larger than 1 in. diameter.  $L_G$  max. represents the minimum design grip length of the bolt and may be used for determining thread availability when selecting bolt lengths even though usable threads may extend beyond this point.

Thread length,  $L_T$ , is a reference dimension intended for calculation purposes only that represents the distance from the extreme end of the bolt to the last complete (full form) thread.

(b)  $L_B$  min. is the distance measured parallel to the axis of bolt from the underhead bearing surface to the last scratch of thread or to the top of the extrusion angle. It shall be used as a criterion for inspection. The minimum body length, as calculated and rounded to two decimal places, shall be equal to the maximum grip gaging length minus the transition thread length ( $L_B = L_G$  max. -  $Y$ ). Bolts of nominal lengths that have a calculated  $L_B$  length equal to or shorter than 2.5 times the thread pitch for sizes 1 in. diameter and smaller, and 3.5 times the thread pitch for sizes larger than 1 in. diameter shall be threaded for full length.

Transition thread length,  $Y$ , is a reference dimension intended for calculation purposes only that represents the length of incomplete threads and tolerance on grip-gaging length.

**6.6.3 Incomplete Thread Diameter.** The major diameter of incomplete thread shall not exceed the actual major diameter of the full form thread.

## 6.7 Spline

The 12 spline dimensions and groove dimensions are reference dimensions and shall be at the discretion of the manufacturer. Users should consult with the supplier to assure wrenchability. Reference dimensions for the spline length and width across flats are given in [Table 6.1.1-1](#).

## 6.8 Point

Unless otherwise specified, bolts need not be pointed. The distance,  $U$ , given in [Table 6.1.1-1](#), is from the center of the groove to the first fully formed thread crest. This shall be determined by measuring how far the point enters into a cylindrical NOT GO major diameter ring gage.

**6.8.1 Groove Diameter.** The groove diameter,  $E_1$ , is approximately equal to 80% of the thread maximum minor diameter (see [Figure 6.8.1-1](#)). The actual  $E_1$  value shall be established by the manufacturer to assure proper function.

## 6.9 Straightness

Shanks of bolts shall be straight within the following limits at MMC:

(a) For bolts with nominal lengths up to and including 12 in., the maximum camber shall be 0.006 in. per inch (0.006L) of bolt length.

(b) For bolts with nominal lengths over 12 in. up to and including 24 in., the maximum camber shall be 0.008 in. per inch (0.008L) of length.

A suggested gage and gaging procedure for checking bolt straightness is given in ASME B18.2.9.

## 6.10 Material and Mechanical Properties

Chemical and mechanical properties shall conform to ASTM F3125/F3125M.

## 6.11 Finish

Unless otherwise specified, bolts shall be supplied with a plain (as-processed) finish, unplated or uncoated. If a finish is required, it shall conform to the requirements of ASTM F3125/F3125M.

## 6.12 Designation

(a) Twist-off-type structural bolt assemblies include a bolt, nut, and washer, and are designated in the following manner: quantity; size, including bolt diameter and length (without the spline end); name of product; head style, Type (1 or 3); specification; coating; and special requirements (if applicable).

EXAMPLES:

- (1) 2,500 assemblies,  $\frac{3}{4} \times 2$ , twist-off bolt/nut/washer assemblies, round head, ASME B18.2.6, ASTM F3125/F3125M Grade F1852 Type I, mechanically zinc coated to ASTM B695 Class 55
- (2) 2,500 assemblies, ASME B18.2.6, ASTM F3125/F3125M Grade F1852 Type I,  $\frac{3}{4} \times 2$ , twist-off bolt/nut/washer assemblies, round head, mechanically zinc coated to ASTM B695 Class 55

(b) For a part identifying number (PIN), refer to ASME B18.2.4.

## 6.13 Product Marking

All components shall be marked in accordance with ASTM F3125/F3125M.

**6.13.1 Identification Symbols.** Identification marking symbols on bolt heads shall be raised or indented at the manufacturer's option, unless otherwise specified. Markings shall be legible to the unaided eye with the exception of corrective lenses. When raised, the height of the marking may not exceed 0.015 in. over the specified maximum head height for bolts  $\frac{5}{8}$  in. and smaller. For bolts larger than  $\frac{5}{8}$  in., the marking may not project more than 0.030 in. over the specified maximum head height. When indented, the depth of the marking shall not reduce the load-carrying capability of the fastener.

## 6.14 Workmanship

The allowable limits, inspection, and evaluation of surface discontinuities, quench cracks, forging cracks, head bursts, shear bursts, seams, folds, thread laps, voids, tool marks, nicks and gouges shall be in conformance with ASTM F788.

## 6.15 Quality Assurance

Unless otherwise specified, products shall be furnished in accordance with ASME B18.18.

# B18

## AMERICAN NATIONAL STANDARDS FOR BOLTS, NUTS, RIVETS, SCREWS, WASHERS, AND SIMILAR FASTENERS

B18.1.1-1972 (R2016)	Small Solid Rivets
B18.1.2-1972 (R2016)	Large Rivets
B18.1.3M-1983 (R2016)	Metric Small Solid Rivets
B18.2.1-2012	Square, Hex, Heavy Hex, and Askew Head Bolts and Hex, Heavy Hex, Hex Flange, Lobed Head, and Lag Screws (Inch Series)
B18.2.2-2015	Nuts for General Applications: Machine Screw Nuts, Hex, Square, Hex Flange, and Coupling Nuts (Inch Series)
B18.2.3.3M-2007 (R2014)	Metric Heavy Hex Screws
B18.2.3.5M-1979 (R2016)	Metric Hex Bolts
B18.2.3.9M-2001 (R2014)	Metric Heavy Hex Flange Screws
B18.2.4.3M-1979 (R2017)	Metric Slotted Hex Nuts
B18.2.5M-2013 (R2017)	Metric 12-Point Flanged Head Screws
B18.2.6-2019	Fasteners for Use in Structural Applications
B18.2.6M-2012	Metric Fasteners for Use in Structural Applications
B18.2.8-1999 (R2017)	Clearance Holes for Bolt, Screws, and Studs
B18.2.9-2010 (R2017)	Straightness Gage and Gaging for Bolts and Screws
B18.3-2012 (R2017)	Socket Cap, Shoulder, Set Screws, and Hex Keys (Inch Series)
B18.5-2012 (R2017)	Round Head Bolts (Inch Series)
B18.6.1-1981 (R2016)	Wood Screws (Inch Series)
B18.6.2-1998 (R2010)	Slotted Head Cap Screws, Square Head Set Screws, and Slotted Headless Set Screws (Inch Series)
B18.6.3-2013 (R2017)	Machine Screws, Tapping Screws, and Metallic Drive Screws (Inch Series)
B18.6.8-2010 (R2017)	Thumb Screws and Wing Screws (Inch Series)
B18.6.9-2010 (R2017)	Wing Nuts (Inch Series)
B18.7-2007 (R2017)	General Purpose Semi-Tubular Rivets, Full Tubular Rivets, Split Rivets and Rivet Caps
B18.7.1M-2007 (R2017)	Metric General Purpose Semi-Tubular Rivets
B18.8.1-2014	Clevis Pins and Cotter Pins (Inch Series)
B18.8.2-2000 (R2010)	Taper Pins, Dowel Pins, Straight Pins, Grooved Pins, and Spring Pins (Inch Series)
B18.9-2012 (R2017)	Plow Bolts
B18.10-2006 (R2016)	Track Bolts and Nuts
B18.11-1961 (R2017)	Miniature Screws
B18.12-2012	Glossary of Terms for Mechanical Fasteners
B18.13-2017	Screw and Washer Assemblies — SEMS (Inch Series)
B18.13.1M-2011 (R2016)	Screw and Washer Assemblies: SEMS (Metric Series)
B18.15-2015	Forged Eyebolts
B18.16M-2004 (R2016)	Prevailing-Torque Type Steel Metric Hex Nuts and Hex Flange Nuts
B18.16.4-2008 (R2017)	Serrated Hex Flange Locknuts 90,000 psi (Inch Series)
B18.16.6-2017	Prevailing Torque Locknuts (Inch Series)
B18.18-2017	Quality Assurance for Fasteners
B18.21.1-2009 (2016)	Washers: Helical Spring-Lock, Tooth Lock, and Plain Washers (Inch Series).
B18.21.2M-1999 (R2014)	Lock Washers (Metric Series)
B18.21.3-2008 (R2017)	Double Coil Helical Spring Lock Washers for Wood Structures
B18.22M-1981 (R2017)	Metric Plain Washers
B18.24-2015	Part Identifying Number (PIN) Code System for B18 Fastener Products

B18.27-1998 (R2017)	Tapered and Reduced Cross Section Retaining Rings (Inch Series)
B18.29.1-2010 (R2017)	Helical Coil Screw Thread Inserts — Free Running and Screw Locking (Inch Series)
B18.29.2M-2005 (R2017)	Helical Coil Screw Thread Inserts: Free Running and Screw Locking (Metric Series)
B18.31.1M-2008 (R2016)	Metric Continuous and Double-End Studs
B18.31.2-2014	Continuous Thread Stud, Double-End Stud, and Flange Bolting Stud (Stud Bolt) (Inch Series)
B18.31.3-2014	Threaded Rods (Inch Series)
B18.31.4M-2009 (R2017)	Threaded Rod (Metric Series)
B18.31.5-2011 (R2016)	Bent Bolts (Inch Series)

The ASME Publications Catalog shows a complete list of all the Standards published by the Society. For a complimentary catalog, or the latest information about our publications, call 1-800-THE-ASME (1-800-843-2763).

# ASME Services

ASME is committed to developing and delivering technical information. At ASME's Customer Care, we make every effort to answer your questions and expedite your orders. Our representatives are ready to assist you in the following areas:

ASME Press	Member Services & Benefits	Public Information
<i>Codes &amp; Standards</i>	Other ASME Programs	Self-Study Courses
Credit Card Orders	Payment Inquiries	Shipping Information
IMEchE Publications	Professional Development	Subscriptions/Journals/Magazines
Meetings & Conferences	Short Courses	Symposia Volumes
Member Dues Status	Publications	Technical Papers

## How can you reach us? It's easier than ever!

There are four options for making inquiries\* or placing orders. Simply mail, phone, fax, or E-mail us and a Customer Care representative will handle your request.

<i>Mail</i>	<i>Call Toll Free</i>	<i>Fax—24 hours</i>	<i>E-Mail—24 hours</i>
<b>ASME</b>	<b>US &amp; Canada:</b> 800-THE-ASME	973-882-1717	customercare@asme.org
150 Clove Road, 6th Floor	(800-843-2763)	973-882-5155	
Little Falls, New Jersey	<b>Mexico:</b> 95-800-THE-ASME		
07424-2139	(95-800-843-2763)		

\*Customer Care staff are not permitted to answer inquiries about the technical content of this code or standard. Information as to whether or not technical inquiries are issued to this code or standard is shown on the copyright page. All technical inquiries must be submitted in writing to the staff secretary. Additional procedures for inquiries may be listed within.

# ASME B18.2.6-2019

ISBN 978-0-7918-7262-8



9 7 8 0 7 9 1 8 7 2 6 2 8



M 1 6 1 1 T